

09/00/69 "Report on the Design of a Floating Airport," by P. Weidlinger.  
(090069...PW)

Report on the Design of a

FLOATING AIRPORT

FLAIR

PAUL WEIDLINGER, CONSULTING ENGINEER

NEW YORK, N.Y.

September, 1969

# Weidlinger Associates

Consulting Engineers

110 East 59th Street, New York, N.Y. 10022

44 Brattle Street, Cambridge, Mass. 02138

---

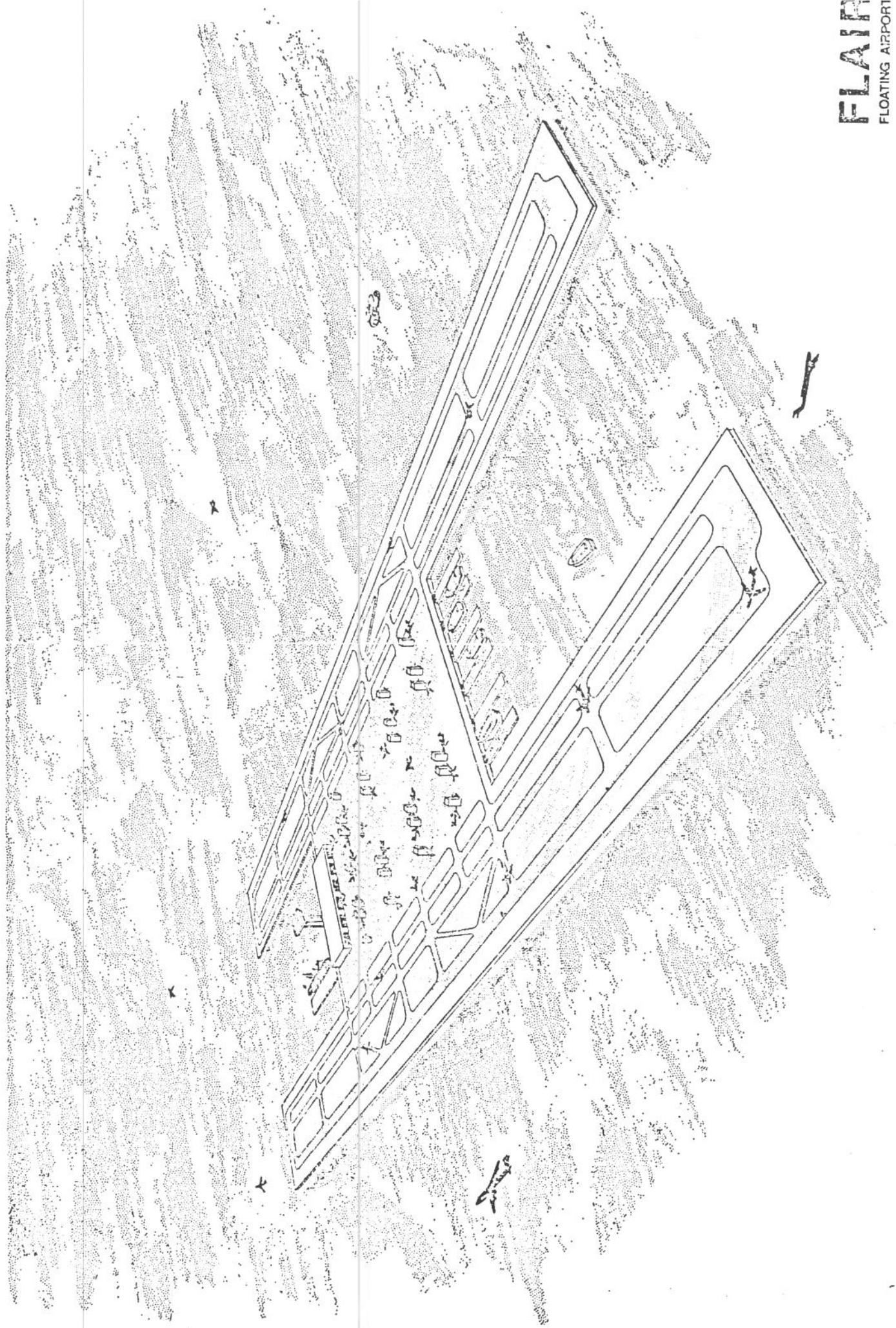

Report on the Design of a

FLOATING AIRPORT

FLAIR

PAUL WEIDLINGER, CONSULTING ENGINEER

NEW YORK, N.Y.

September, 1969



TABLE OF CONTENTS

	ACKNOWLEDGMENT	
	SUMMARY	1
I	INTRODUCTION	2
II	FLOATING AIRPORT CONCEPT: FLAIR	5
III	GENERAL DESCRIPTION	8
IV	MATERIALS, COMPONENTS AND DETAILS	12
V	DESIGN CRITERIA	19
VI	ANALYTICAL PROCEDURES	27
VII	CONSTRUCTION - FABRICATION - POSITIONING	33
VIII	QUANTITY AND COST ESTIMATES	38
IX	CONCLUSIONS	45
	REFERENCES	48
	APPENDIX A	49

LIST OF FIGURES

Figure 1	Assumed Contact Area of Landing Gear	20
Figure 2	Model of Structure - Cross Section	30
Figure 3	Model of Structure - Longitudinal Section	31
Figure 4	Cost vs. Depth	44
Figure 5	Airport Configurations	47

LIST OF DRAWINGS

- 1 PLAN
- 2 SUB-DIVISION OF STRUCTURE
- 3 MODULE
- 4 TYPICAL CROSSECTION
- 5 DECK FRAMING : SUB-STRUCTURE
- 6 BUOYANCY CHAMBER WALLS : ANCHORAGE SYSTEM
- 7 VACUUM CHAMBER - HORIZONTAL SECTION : VERTICAL SECTION
- 8 APPROACH TO SITE
- 9 MANEUVERING BY CABLES
- 10 MODULE ALIGNMENT

## ACKNOWLEDGMENT

This report is the result of a study sponsored by I.D.A. under Contract No. 15747 dated 3 January, 1969. The study was executed by the following members of the firm of Paul Weidlinger, Consulting Engineer :

Istvan Varga  
Mario G. Salvadori  
Paul Weidlinger

The authors acknowledge the numerous contributions of Dr. Richard Garwin of I.D.A. and Watson Laboratories (Columbia University), and especially his concept of the taut cable anchorage of the platform.

SUMMARY

The technical feasibility of designing and constructing an off-shore, floating airport facility is demonstrated. The concept as developed in the report is called FLAIR. It consists of an assembly of a large number of modular units, containing a deck structure supported on submerged flotation chambers which are anchored by taut cables to mass anchors located at a depth of 200 to 600 feet.

It is found that :

- a. Construction of such an airport is feasible by means of state of the art techniques.
- b. The cost of the airport is 1.1 to 1.4 billion dollars, averaging \$30.00 per square foot.
- c. A major problem yet to be studied is that of the airport-to-shore transportation system.

The purpose of this report is to provide factual information as a contribution to the subject of airport construction in the neighborhood of high density urban centers.

## I INTRODUCTION

The unprecedented growth of air travel and the development of larger and faster aircraft, demand new approaches to airport design. Many existing facilities are currently filled to capacity or will be in the near foreseeable future; yet expansion in most cases is not practicable. Real estate within reasonable proximity to large cities is expensive, if at all available, and the acquisition of land is gradually becoming the central and certainly most time-consuming aspect of airport planning. Neighboring communities mount powerful objections to the danger, noise and pollution which are, to some degree, unavoidable by-products of large, modern airports.

In the search for alternate viable solutions, one must consider an airport located on the sea or in other large bodies of water. This study addresses itself to the concept of a floating airport (FLAIR) to be located off-shore in relatively deep water (200 to 500 feet) but close enough to population centers. The purpose of this study is essentially four-fold :

1. To explore and, if possible, to demonstrate the practical feasibility of such a project;
2. To explore and to identify significant theoretical and practical problems which should be studied in greater depths;
3. To identify specific additional problems which arise out of the use of the sea-based airport,
4. To obtain an approximate estimate of cost.

In order to achieve these objectives, a complete preliminary design of a floating airport was carried out. The theoretical and practical problems were sufficiently explored to draw the following conclusions with adequate confidence :

1. The technical feasibility of the concept of the floating airport in general, and the one which is proposed in this report specifically, is within the present state of the art. It is within current practice of civil engineering and ocean engineering.
2. The one major, and so far not sufficiently studied problem, is that of airport-to-shore transportation of passengers and, also, to some extent, of cargo.

After the above-mentioned problem is solved, the floating airport concept should be economically justified, in fact, it may become inevitable. The solution recommends itself in appropriate geographic locations of areas of high traffic density.

The most obvious advantages of the off-shore locations are :

1. The readily available unlimited area for an optimal design and space for later expansion.
2. Insertion of new flight patterns that do not interfere with the existing ones.
3. Elimination of danger, noise and air pollution to populated areas.

The major objections to the proposal are :

1. Total cost of the project is generally higher than that of its land-based counterpart. (Such a comparison may not be valid in the near future as construction costs are reduced by improved techniques and as available dry-land locations are exhausted).
2. Connected with the above objection is the lack of experience with the construction and maintenance of ocean-based structures of comparable scope; (undersea tunnels, floating bridges, drilling platforms are being designed in increasing numbers and this will contribute to the knowledge and experience in this rapidly growing field).
3. Finally, there is the previously mentioned issue of providing for an efficient transportation system for passengers and cargo between the airport and various shore locations. (Solutions must be explored in the area of modern and rapidly developing transportation methods: by air through VTOL, STOL and ATOL (Ref. 1); by sea through high-speed surface craft and hovercraft, and also by high-speed rail transportation through causeways or tunnels, possibly by adopting for this purpose the very same techniques which are used in the construction of the airport itself).

It should be noted that if the airport-to-shore transportation is solved by means of aircraft or surface craft, the solution will lead to the dispersal of passengers and cargo to numerous land-based sub-terminals, eliminating thereby some of the traffic problems associated with ground transportation of land-based airports.



## II FLOATING AIRPORT CONCEPT: FLAIR

The most obvious and best-known example of a floating airport of course, is the aircraft carrier. However, because of its much smaller size (about 1,000 ft. as compared to 12,000 ft.) and also because of its military operational requirements which differ from those in civilian aviation, the design of a floating platform, such as is envisioned in this report, presents special problems as follow :

1. The structural integrity, i.e. strength, of very large floating objects, require solutions which differ from those used in the design of hulls of large vessels.
2. The stability of the platform to be used as civilian airport (or for large aircraft in general), must be such that it admits standard take-off and landing procedures.
3. The platform should be able to keep its position within the accuracy required for normal landing, take-off and navigation of land-based aircraft.

The idea of such a stable platform is believed to have originated more than 30 years ago by E.R. Armstrong, and it culminated in a proposal called the "Seadrome", which was to be used for transatlantic flights (Ref. 2). Since that time, several applications for floating airports have been investigated.

To the best of our knowledge, the majority of these proposals have in common the notion of a submerged buoyancy chamber (originally proposed by Armstrong), which supports a platform constituting runways and other

facilities. The submerged buoyancy chamber is located at a distance below the surface which places it for all intents and purposes, below the wave base and, therefore, minimizes the buoyant volume of the structure which is subjected to wave motion. Only the parts connecting the submerged buoyancy chamber with the deck are subject to buoyancy variation due to waves. This idea, by reducing the bending in the hull, makes practical and, in effect feasible, the construction of the extremely large floating platforms. Such dimensions would not be practical by the conventional hull structure of surface vessels.

In addition to this the buoyancy chamber which is submerged below the wave base, substantially reduces the heaving motion of the platform. (Ref. 3). In Armstrong's design and in some other proposals, a further increase of vertical stability is achieved by automatically pumping fluid between inter-connected vertically-stacked buoyancy chambers. In many applications this additional stabilization procedure is dispensed with and it is assumed that adequate stability is achieved by placement of the chambers at a sufficient depth below the surface. The positioning or station-keeping of some such designs is achieved by rather large auxiliary power plants which provide sufficient speed (4 to 8 knots) for positioning purposes. Even at this low speed, the power requirements of the propulsion units are substantial (180,000 H.P.).

The FLAIR design utilizes many ideas of these early concepts, with an additional improvement in the design which is based on ideas developed by Richard Garwin of IDA: Increased stability and station-keeping ability is achieved without the use of power source.

The FLAIR concept consists of a platform (positioned above the surface at a distance to ensure that the deck will not be awash under most severe sea conditions) and connected by means of vertical columns to buoyancy chambers located essentially below the wave base. The deck, plus buoyancy chamber combination, together with all super-imposed loads, has a large positive buoyancy. This buoyancy then will tend to raise the platform and elevate the chambers to the surface of the water. The whole structure is vertically restrained, however, by means of taut mooring cables. These cables (which are connected to mass anchors), therefore, are continuously under substantial tension, providing thereby what could be termed a pre-tensioned foundation system. This type of tensile foundation system in itself, makes it possible to place the FLAIR platform into a depth of water of 200' or more. Such depth is beyond that which is practicable if a conventional pile or caisson foundation would be used. At the same time, because of the high prestress in the taut cables, the platform is stabilized not only vertically but also laterally. Wave motion and drifting are all but eliminated and all distortions or motions are only those which are associated with elastic deformations of the structure. The anchoring of the floating structures is, of course, not new and has been used for floating bridges. The Hood Canal Floating Bridge (Port Gamble, Washington, designed by Howard, Needles, Tammen and Bergendorf) for instance, is anchored to a maximum depth of 330' and the maximum length of anchor cables which extend laterally is 1200'. However, the idea of taut cables achieved by the excess buoyancy of the chambers is new, especially in its application to the FLAIR concept. This provision eliminates the need of the power plant and as it turns out, facilitates the entire construction and erection procedure.

### III GENERAL DESCRIPTION

#### Location:

In order to produce a more realistic preliminary design study of the FLAIR concept, the task of the preliminary study has been set as that of a new airport for the New York Metropolitan area. Problems of air transportation in this location are assuming critical dimensions. The air space, even at the current demand, is nearly saturated, and the ground transportation between the existing airports and the terminals are congested, yet a lasting solution at the time of writing this report, is not in sight. Expansion of present facilities can, at best, ensure temporary relief and may trigger even larger problems at a later time. The idea of proposing an airport in the Atlantic Ocean within the area of the Continental Shelf at a distance of 40 - 50 miles from New York City, appears to be attractive. The location of the airport could be selected to avoid interference with surface navigation and existing air traffic patterns and, at the same time, the requirements for anchoring of the platform and its relation to the fabricating plants located on-shore, can be satisfied. Of course, similar conditions can be found in other locations in the United States and floating airports are also being considered in other countries. The concept as outlined in this design is, therefore, valid for many other off-shore locations.

#### Configuration:

The typical cross-section of the FLAIR platform as shown on Drawing 4, shows the following basic components :

- a. Superstructure and deck - 26 feet above mean water level.
- b. Vertical columns and bracing.
- c. Buoyancy chambers.
- d. Mooring cables.
- e. Mass anchor (located at a depth of 400 feet and beyond).

The plan of the proposed airport is shown on Drawing 1. It occupies a space of 12,000 feet by 5,600 feet and has a total surface area of over 1,000 acres. It contains the following facilities :

- 2 - 12,000' long parallel runways
- 4 - Parallel taxiways

Hardstand Parking and Hangar area provides -

Gate positions for: 60 A/c.

Parking space for: 36 A/c.

Maintenance Hangars for: 12 A/c.

Total Area: 290 acres

Maximum number of  
aircraft movements: 100 per hour.

The schematic plan of the airport deck and the subdivision of the structure is shown on Drawing 2. The deck is subdivided by a series of expansion joints into 1200 ft. long units; each unit is built of 200 ft. x 200 ft. modules that represent the basic structural elements of the airport. Drawing 3 shows an isometric view of the module and identifies its components. Drawing 4 is a typical cross-section.

The airport is designed to satisfy the requirements of current Jumbo aircraft (B-747). In addition to that, provisions can be made for the accommodation of VTOL and STOL aircraft and two locations are provided for harbors to accommodate surface craft for cargo and tankers, and small surface craft for passengers. Passenger and cargo movement are foreseen as being located entirely below deck. This disposition will permit a multi-level terminal designed with greatly improved passenger facilities. Cargo and POL storage is also located below deck.

Design Philosophy:

The airport is designed to be operational in severe sea conditions. The structure will survive winds of 130 m.p.h. and 40' high waves. The design itself can be adapted to more severe conditions, that is, for higher waves by increasing the height of the platform above the sea level and increasing the depth of the buoyancy chambers. The anchoring system will withstand currents and tides encountered in off-shore locations. Generally, the design philosophy may be summarized in the following points :

1. Conservative design assumptions to achieve maximum safety and reliability.
2. Flexibility of the design to admit future expansions, alterations and retro-fitting.
3. Application of the concept to other types of off-shore structures, such as satellite airports, heliports, STOL and VTOL airports, and causeways.
4. Use of readily available construction materials, adequately tested in marine environment.

5. State of the art construction procedures geared to a high level of prefabrication, use of standard equipment and elimination of under-water construction work.

#### IV MATERIALS, COMPONENTS AND DETAILS

The structure consists of relatively few and simple components. The materials are those commonly employed in civil engineering structures: Reinforced concrete and structural steel.

##### Materials:

Structural components are designed according to standard procedures described in the current ACI and AISC building codes. Specifications of the principal materials used are summarized below:

TABLE 1

##### Materials

<u>Materials</u>	<u>Strength</u>	<u>Use</u>
Reinforced Concrete (Cast in Place)	$f'_c = 5000$ psi	Buoyancy chamber walls 6" wearing surface Mass anchor "box"
Prestressed Concrete (Precast)	$f'_c = 6000$ psi	14" deck panels Buoyancy chamber domes
Reinforcing Bars	$f_s = 24000$ psi	All concrete
Prestressing Tendons	$f'_s = 250000$ psi	Prestressed concrete
Structural Steel U.S.S. Mariner or equivalent	$f_y = 50000$ psi	Deck framing Columns and Diagonals
Cables 4-1/4" $\emptyset$ zinc coated marine cables	breaking strength = 594,000 lbs.	Mooring cables

Most of the concrete surfaces that are exposed to sea water are precast and also prestressed (spherical domes of buoyancy chambers, deck, etc.) and they are expected to be of a uniformly high density. Service life



in excess of at least 25 years can be anticipated, during which period no repairs are necessary, since properly controlled reinforced concrete exhibits high resistance to marine environment. (Ref. 4).

There is also information on the performance of high strength structural steels in the marine environment, in the form of data compiled regarding behaviour of steel sheet piling. Corrosion rates are the greatest in the splash zone where the steel surface is alternately exposed to air (oxygen) and sea water. This type of exposure will be experienced in the FLAIR structure at the central portions of the tubular steel columns. If the column is not specially protected in this zone, (concrete jacket, paint), its service life is controlled by the deterioration of this section.

Experiments performed on the U.S.S. Mariner steel in an environment similar to the one described above, indicate that the maximum loss in thickness is 87 mils in a period of 5 years. (Ref. 5). Based on an average corrosion rate of 10 mils per year, the present design allows a 10% loss of material without endangering the safety of the structure, and through an increase of the cross-section in the splash zone by 10%, the expected life time is 25 years, which is consistent with the resistance of concrete components.

Corrosion rates of steel members constantly above the water surface are considerably less. The use of special protective coatings may be practical since these members are easily accessible for inspection and repair if it should be required.

The mooring cables (zinc coated marine cables) are fully-submerged at all times and deterioration is expected to be negligible during the service life of the structure.

Components and Details:

The principal components of the structure as identified on Drawing 4 are as follow :

1. Precast Slab with Wearing Surface

- a. The surface of the platform consists of partially prestressed precast slabs with an integral wearing surface. The slab serves two purposes: To transmit load to the supporting steel members, and to act as the compression flange of the composite steel framing.
- b. Dimensions of the reinforced concrete precast panels are 15'8" x 15'8" x 14". Each panel weighs 22 tons. They contain shear connectors which are welded to the supporting angles. When the panels are placed on the beams they are integrally joined by welding. The panel contains 8 p.s.f. of mild steel and 3.7 p.s.f. of high strength strands.
- c. The panels are designed as simply-supported square plates. Since the super-imposed load (landing gear) is much higher than the dead load, the prestressing is not very effective. On the other hand, prestressing reduces potential cracking and ensures that the panels are resistant to corrosion and are stable during transportation and handling. The maximum bending moment (41 k.ft./ft.) occurs when the landing gear is centered on the slab.

## 2. Deck Framing (Drawing 5)

- a. The deck framing consists of a structural steel grid of a square mesh of 16'8" x 16'8", corresponding to that of the precast panels which it supports.
- b. The framing system is detailed with routine field connections. The framing is sub-divided into 50' x 50' units which are supported on steel columns. The grid members supporting the precast panels consist of 36WF230 steel beams which, in turn, are connected to the 50' span girder sections consisting of built-up plate girders with 30" x 2-1/2" flanges and 60" x 7/16" webs. The steel framing weighs 36 p.s.f.
- c. The members are designed for critical positions of the landing gears. The maximum moment in the beams is 3,100 k.ft./ft. and in the girders 7,900 k.ft./ft.

## 3. Columns and Diagonals

- a. The columns support the deck structure and transmit the load into the buoyancy chambers. In addition to that, the columns together with the diagonal members, provide the lateral stiffness for the connection between deck and buoyancy chamber. Circular steel sections are used for the columns for a minimum surface exposure to wave and wind forces. Variation in the submerged volume due to wave action is also kept to a minimum, consequently the bending introduced by variation of the buoyant forces is small. The tubular section has a small corrosion rate, because of the favorable surface to cross-section area and lack of sharp corners.

b. The columns and diagonals consist of 20" diameter steel tubes of a wall thickness of 1-1/4", weighing 267 lbs./lineal ft. The columns and diagonals contribute 7.00 p.s.f. to the weight of the structure.

c. The column load is a maximum when the center of gravity of the aircraft is directly above it and it is subjected to a concentric load of 1500 kips. In addition to that it is subjected to 10.00 k./ft. of bending moment due to wave action and other lateral forces.

#### 4. Buoyancy Chambers

a. Buoyancy chambers act as a continuous elastic "foundation mat" supporting the columns. They also fulfill the following functions :

- (i) Provide overall rigidity by distributing locally applied forces through reducing local deformations.
- (ii) Provide the necessary uplift to resist vertical loads and provide the required tension, i.e. prestress in the mooring cables.

To meet the above requirements, a series of sealed chambers are provided. These chambers are constructed of a square grid system in the form of an egg-crate and are sealed at the top and bottom by spherical shells.

b. The chambers are constructed in reinforced concrete. The egg-crate like grid system consists of reinforced concrete walls 25' on center in both directions with a depth of 13' to 15'.

These are covered by spherical domes to provide 25' x 25' water-tight chambers, thus localizing the effects of possible leakage.

The spherical domes are partially prestressed precast reinforced concrete elements of 8" thickness. Each of these units weigh 35 tons. The prestressing serves the purpose of minimizing cracking due to shrinkage and handling. To ensure reliable performance, water-tightness of the exposed surfaces must be insured. This is achieved by the proper choice of mix and adequate curing procedures. No special water-proofing is introduced. (Ref.4).

c. The principal loading on the vertical grid walls is bending in the vertical plane. These walls are designed to distribute the load between the columns to the mooring cables. The maximum moments and forces acting on the walls is 20,000 k.ft.

The spherical dome closures are subjected to a nearly uniform hydrostatic pressure. Pressure is resisted primarily by membrane-type compression stresses. The maximum membrane stress is 760 psi.

#### 5. Anchorage System (Drawings 4 and 6)

a. The anchorage system consists of the mooring cables and mass anchors and it serves a twofold purpose :

- (i) It stabilizes the structure both vertically and horizontally.
- (ii) It aides the assembly of modules on the site.

Each module has its own stable anchorage system consisting of four slightly inclined mooring cables attached to a single mass anchor resting on the ocean bottom. The arrangement is shown on

Drawings 4, 9 and 10. At least three cables are necessary for stability, however, for ease of positioning and also to obtain redundancy, four cables are used.

By mooring each module, both vertical and horizontal forces are distributed over the entire structure. Since the system is highly redundant, a number of simultaneous cable failures will not cause overall failure.

Once the modules are integrally connected, horizontal forces are resisted by a frame-type action, due to the inclination of the cables. Due to the prestress, tension is maintained under lateral forces, and because the four cables are attached to the same anchor, the uplift of the anchor is constant.

The structure can be modelled as a plane grid resting on elastic springs. The springs chosen are soft compared to the stiffness of the grid and, therefore, locally applied loads are distributed over a number of springs, i.e. cables.

b. The cables consist of 4-1/4" diameter zinc coated marine cables. The mass anchor is a square concrete box (35' x 35' x 15') and is filled in place with concrete. The total weight of the submerged anchor is 2,150 kips. Actual details and dimensions of the anchor, of course, will depend on the configuration and properties of the bottom surface.

c. The maximum force in the cable is 340 kips which is resisted with a factor of safety of 1.75. The maximum vertical force on the anchor is 1,360 kips and the maximum lateral force is 70 kips.

## V DESIGN CRITERIA

The FLAIR structure is designed to accept currently operational or planned aircraft in all weather conditions. It is designed to survive storms without damage and to preserve structural integrity in case of accidental failure of some of its components. Provisions are made for repair and service.

The loads which are resisted by the structure are :

1. Service loads.
2. Forces during construction.
3. Environmental forces (wind, sea, temperature).
4. Survival loads, accidental forces.

### 1. Service Loads

These are loads pre-imposed on the structure by parked or moving aircraft. For purposes of the prototype design the Boeing 747B aircraft is considered as being typical. (Ref. 6 and Ref. 7).

TABLE II

Weights and Dimensions (Boeing 747B)

Maximum take-off weight	775,000 lbs.
Maximum landing weight	564,000 lbs.
Maximum static load on nose gear	81,000 lbs. (*)
Maximum static load on main gear	182,000 lbs. (*)
Length	231'-4"
Wing Span	195'-8"
Maximum Height	63'-0"

(\*) Calculated from total static weight of 710,000 lbs. to 775,000 lbs.

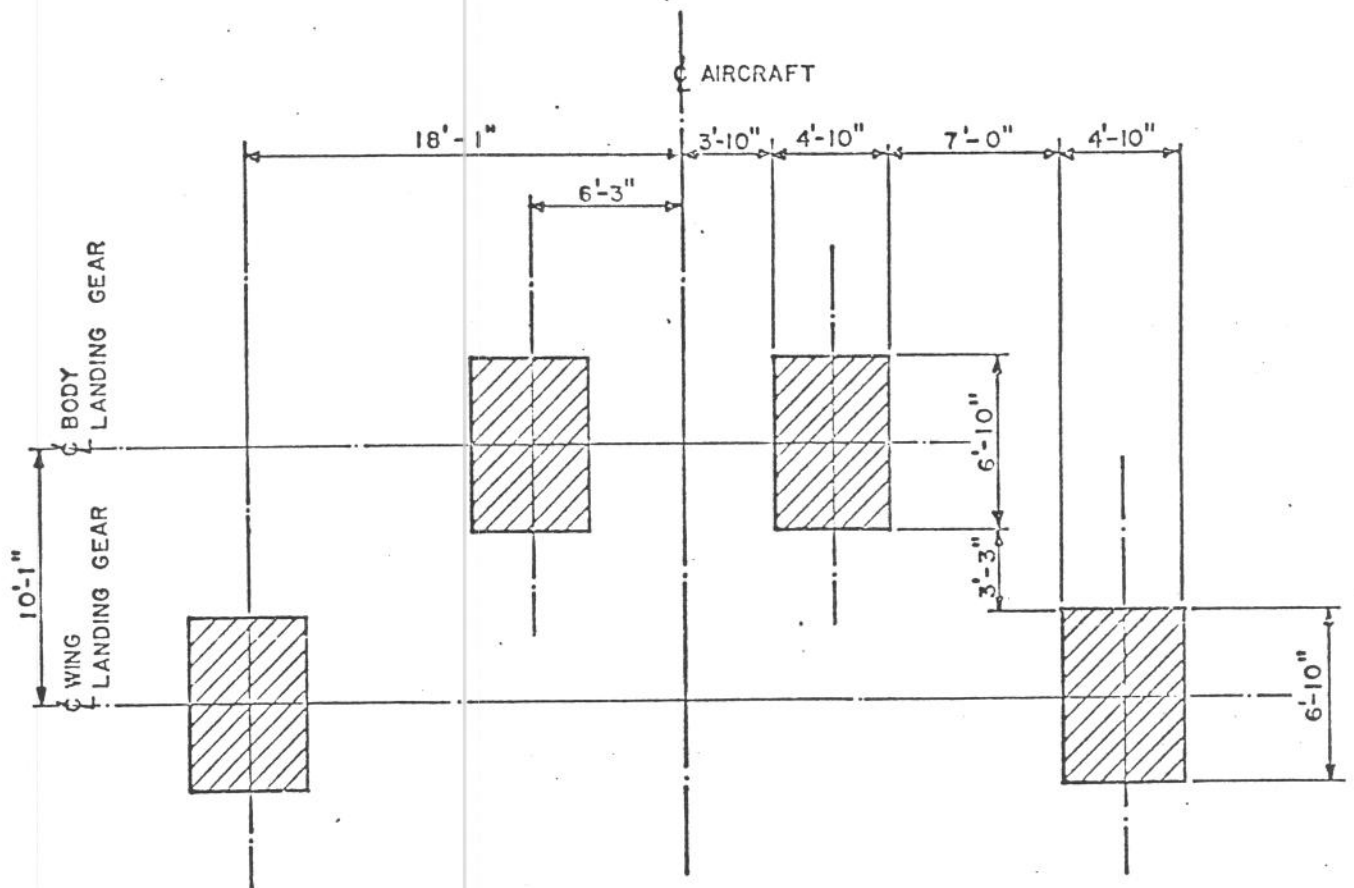

FIGURE 1. - ASSUMED CONTACT AREA OF LANDING GEAR.



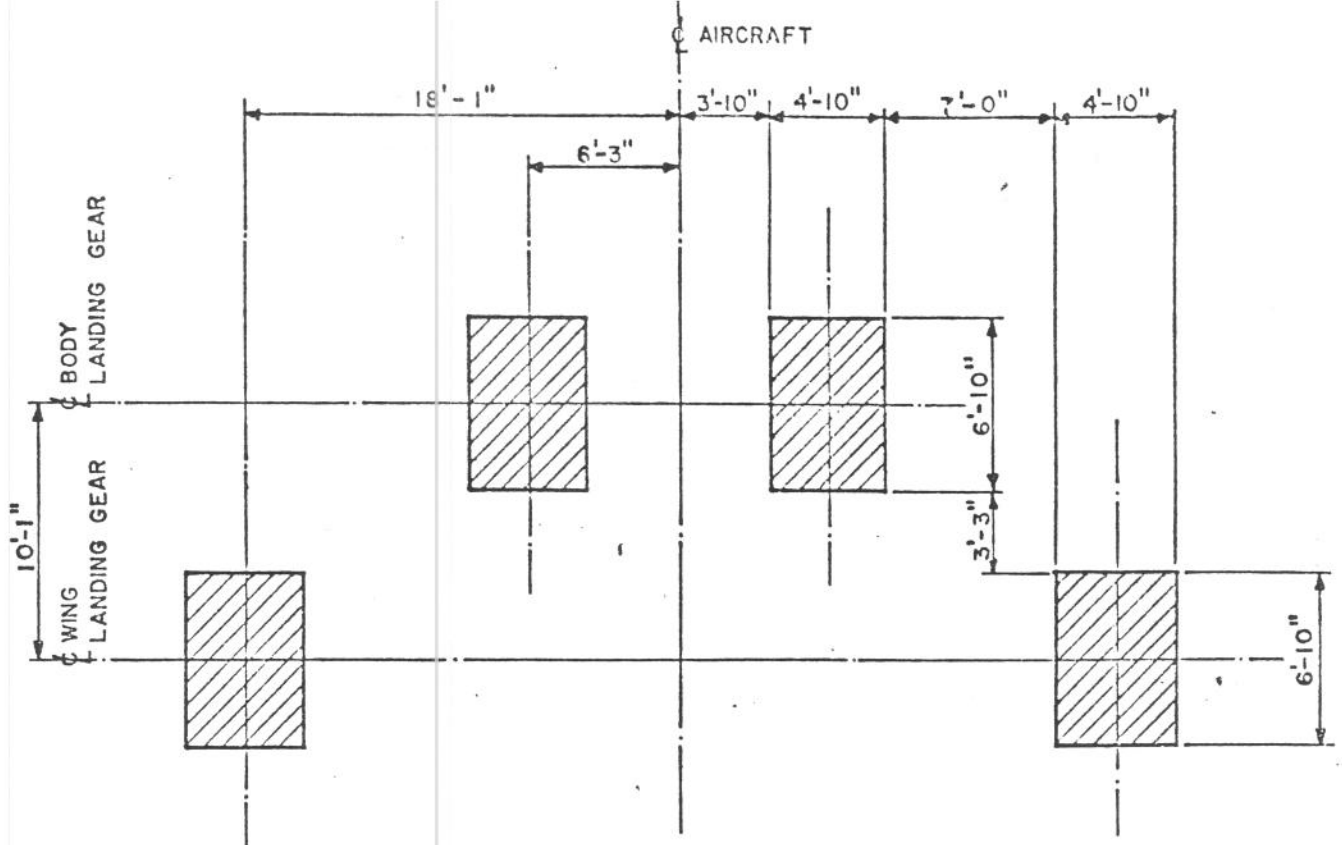

FIGURE 1. - ASSUMED CONTACT AREA OF LANDING GEAR.

Fig. 1 shows the contact area of the main landing gear.

The weight of the aircraft is increased by impact loads as percentages of maximum take-off weight on various structural components as follow :

TABLE III  
Impact Factors

Steel Concrete Composite Deck	37%
Impact during taxi-ing	37%
Impact during landing (end portions of runway)	94%
Columns	37%
Buoyancy Chambers, Anchorage System:	No impact

The impact factor applied to the deck was obtained from published results of experiments, performed in connection with the design of the La Guardia runway extension in 1964. (Ref. 8).

The impact factor was assumed to be zero for the buoyancy chambers and the anchorage system, because of the inertial effect of the large mass of the chambers and the apparent mass of surrounding water and viscous damping effects.

## 2. Forces during construction

While the module is being towed from the shore to the airport site, it has to resist forces due to :

- a. Towing
- b. Waves.

a. Forces due to towing

The module is towed along a diagonal of the 200 ft. x 200 ft. module as shown on Drawing 8. The towing cable is attached to the leading corner of the square. The maximum cable force of 90,000 lbs. is determined by the speed of travel (4 knots). The pull is reacted by pressure along the four sides of the square. The stability of the system during towing is satisfactory.

b. Forces due to waves

While the module is in tow, the buoyancy chamber is only partially submerged, therefore, waves produce bending moments in the chamber walls. Since only a 5 ft. portion of the chamber rises above the water line, the critical wave height for the travelling module is 10 ft. or smaller.

3. Environmental Forces

Recent developments in construction of off-shore oil drilling platforms have contributed a great deal to the knowledge of relevant environmental forces, but not all such data are directly applicable to structures of the size and configuration of the suggested airport. To obtain more reliable information, a series of model tests will be necessary. Since experiments are beyond the scope of this report, conservative estimates of the forces are used in the design.

The environmental forces considered are :

- a. Vertical and lateral forces due to waves
- b. Lateral forces due to currents and tides
- c. Lateral forces due to wind
- d. Forces due to temperature variations.

a. Vertical and lateral forces due to waves

An important feature of the design is that the buoyancy chambers remain fully-submerged at all times. This ensures that the submerged volume and, consequently, the buoyant force, are weakly dependent on the wave profile variation. Only variation due to partial submergence of the steel columns supporting the deck need to be considered, resulting in a net vertical force of 1,900 lbs./column.

Lateral forces due to waves are also acting on the steel columns. The magnitude of the force is based on data used in the design of off-shore drilling units. (Ref. 9). A horizontal force of 50 lbs./ft. is assumed to act on any one column along its entire length, applied to one half of the total number of columns simultaneously.

b. Lateral forces due to currents and tides

Since the location of the airport is not determined, a representative maximum current velocity of 2 knots is assumed, resulting in a total lateral drag force on entire structure of 3,550 kips.

c. Lateral forces due to wind

The static wind pressure to be resisted by the anchorage system is based on a wind velocity of 130 mph. (Ref. 10). The resulting

pressures are: 50 psf on vertical surfaces; 0.03 psf on horizontal surfaces of the top and bottom of deck. (Ref. 11). The maximum total lateral force due to wind is 35,000<sup>k</sup> lbs. on the entire structure.

d. Forces due to temperature variations and gradients

The top of the deck is subject to the effect of radiant and ambient air temperature. In contrast, the steel framing supporting the deck is well protected. The water surface, 19 ft. below, serves as a heat reservoir during the winter, while it absorbs heat during the summer. The temperature variation of the buoyancy chambers is significantly less, due to the protective water shield above.

Based on temperature variations of air and the ocean in the New York area, the following design values are used :

± 30°F gradient across deck and buoyancy chambers

± 15°F fluctuation in buoyancy chambers

20°F to 100°F on deck surface.

4. Survival loads - accidental forces

a. Waves

The design wave height is 30 ft.; the deck will not be awash during waves of 40 ft. Larger waves will produce increased lateral forces, but its effect is local and does not increase appreciably the total lateral force on the anchorage system.

b. Damage by ships

There is the danger of a ship colliding with the structure. The most critically exposed areas to surface navigation are the exterior shoulders along the runways. These 225 ft. wide shoulders support nominal live loads. Their principal function is to provide the desired ground effect for the airborne aircraft. Should a collision occur, the ship would have to destroy a section of this shoulder strip before damaging the runway itself, thus the vital parts of the airport are provided with protection. It is estimated that a lateral equivalent static force of 25,000 kips can be absorbed.

c. Crash landing

The impact factor on the runway during crash landing is assumed to be 300 to 400% of the weight of the aircraft. (Ref.8).

Applying this impact factor to the landing weight, the maximum stresses are found to be at yield. Since the impact below the deck is decreased, stresses in the sub-structure remain in the elastic range. If a crash of exceptional intensity should destroy the deck, the buoyancy chambers will be protected by a 19 ft. water shield.

d. Local failure of Buoyancy Chambers or Mooring Cables

In the design of buoyancy chambers, provision is made for modifying the uplift. This can be achieved by partially flooding the chambers. The depth of water in the chambers is 2.5± ft. Stresses in the mooring cables are to be monitored and pumps may be activated to increase or decrease the uplift.

If a chamber fails, cable stresses in that area drop and the necessary uplift can be restored by reducing the ballast in the adjacent chambers. Using the same device, cable failure can also be handled. Cable failure results in an increase in the net uplift, consequently, the water level in the surrounding chambers has to be increased. While these temporary ballasting measures are in effect, the damaged parts may be repaired.

## VI ANALYTICAL PROCEDURES

For purposes of static and dynamic analyses, the structure may be described to behave in one of the following two modes :

1. For loads producing primarily vertical displacement, the model of the structure is that of an elastic grid (super-structure plus buoyancy chambers) supported on elastic foundation or on elastic springs (prestressed mooring cables).
2. For loads producing primarily horizontal displacement, the equivalent structure is that of an elastic frame consisting of horizontal members (deck plus buoyancy chambers) and slightly inclined supporting elastic bars (pretensioned mooring cables).

Because one of the purposes of this report is to establish the only basic feasibility of the structure and to provide an approximate quantity take-off and cost estimate, the analysis is simplified.

A major effort of the preliminary study concentrated in isolating areas of uncertainty and problems for which routine procedures may not be applicable or are not directly available. These could probably be grouped into three areas :

1. Aerodynamic and hydrodynamic considerations to determine load inputs.
2. Dynamic effects due to environmental forces and due to aircraft movements.
3. Thermal effects.



It must be noted that there are no adequate analytical procedures available to determine with sufficient precision the forces imposed by various types and combination of wave types and wind. These problems will have to be tackled at a later date by semi-empirical methods. In the meantime, reasonable and generally conservative assumptions were made. However, because of the uncertainty inherent in these assumptions, detailed or refined analytical procedures were not warranted. It was found that with the exception of certain aircraft movements, many dynamic considerations could be treated through equivalent static loadings, subject to routine calculations.

Considering the elastic deformation of the platform during the take-off roll of the aircraft, the effect of the local deformation under the landing gear was treated in more detail. The weight of the aircraft produces a local depression in the deck due to the elastic give of the super-structure and the elastic foundation. An investigation was made to determine whether this phenomenon may not adversely affect the take-off characteristic of the craft by producing excessive "uphill" resistance. Analysis shows that the horizontal resistance produced is negligible. (See Appendix A).

The effect of a thermal gradient, that is the temperature differential existing between the deck and the submerged buoyancy chamber, may produce sufficiently high strains in the members of the structure and in the cable system itself. An analysis of this problem has led to the decision to introduce expansion joints and articulations into the deck structure.

The various static analytical procedures could be performed on a simplified model. While the actual structure could be described as a space frame, containing well over 40,000 joints, a highly simplified model containing only essential portions of the whole system, led to the analysis of a plane frame which by symmetry and anti-symmetry, reduces to 37 joints. (Fig. 2).

Consider the plan of the airport which is in the form of a capital H. The plane frame represents a 100 ft. wide "slice" taken across the leg of the "H". Critical loading conditions are studied on this model with the aid of a computer. When required the gravity loads are adjusted to compensate for the two-way action of inter-connected plane frames. It is assumed that all lateral forces act in a direction perpendicular to the runways and that each 100 ft. wide "slice" resists those forces independently of the adjacent frames. The latter assumption is quite accurate towards the ends of the runways, but becomes very conservative when applied to the center portion of the structure. Lateral forces acting in the longitudinal direction are not critical, and no allowance is made for this effect in the preliminary design.

The analysis and design for gravity loads was performed for those areas of the runways and taxiways which are subject to the maximum equivalent static loads due to 37% impact. The results obtained are adjusted in the quantity take-off to take into account the reduced severity of the loading in the remaining major portions of the platform.

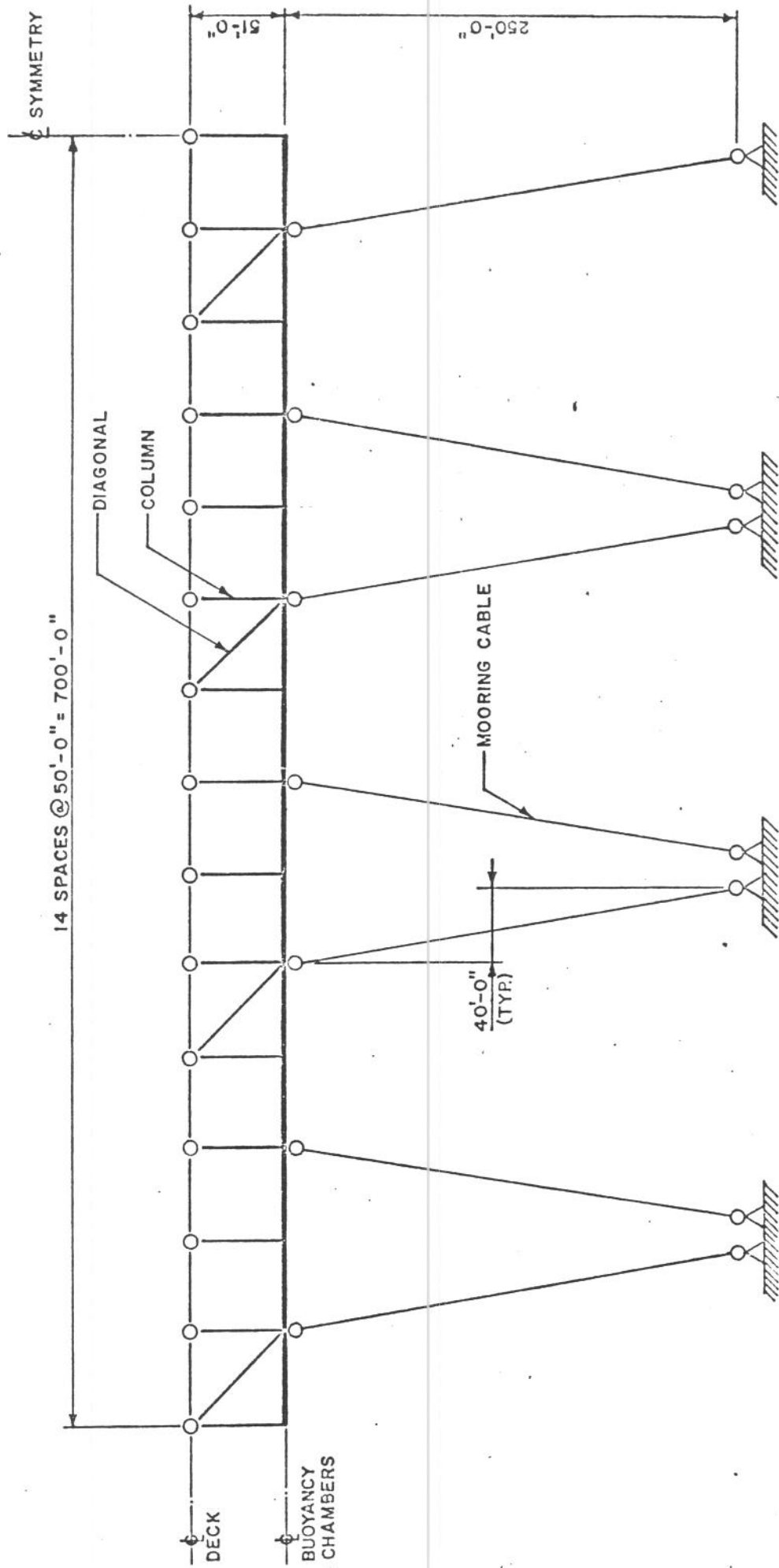

FIGURE 2.- MODEL OF STRUCTURE - CROSS SECTION

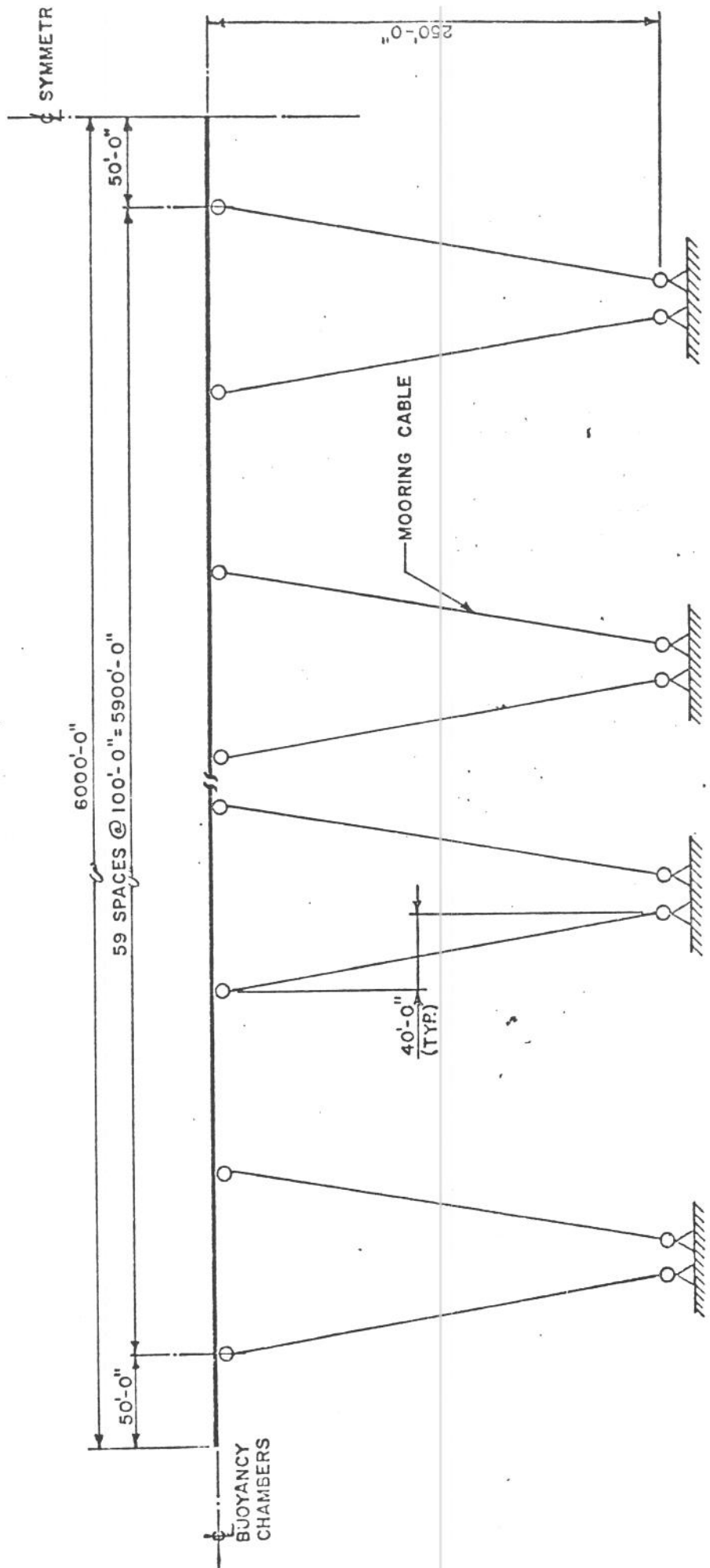

FIGURE 3.- MODEL OF STRUCTURE - LONGITUDINAL SECTION

(FOR THE ANALYSIS OF TEMPERATURE FLUCTUATIONS  
IN THE BUOYANCY CHAMBERS)

The final design as presented in this report, is the result of a series of preliminary studies and a number of parametric investigations. The most critical of these is the establishment of the optimal stiffness ratio between the equivalent elastic grid and the elastic foundation. The results of these preliminary parametric studies led to the particular configuration and dimensions adopted in this report.

## VII CONSTRUCTION - FABRICATION - POSITIONING

The project requires special attention to construction details to facilitate the fabrication, erection and positioning on high seas of the 16 million tons of concrete and steel. The details have been worked out to eliminate the need for exotic materials or construction practices. Positioning of the sub-assemblies dispenses with underwater work; transportation is accomplished by means of standard towing operations.

To achieve maximum prefabrication and ease of assembly, a unit of construction of a 200 ft. x 200 ft. square module is selected. The elements of the module and the construction techniques of each element were described previously. The construction procedures of the modules and that of the entire airport structure are as follow :

### 1. Prefabrication

Construction starts with the building of a dry dock type precasting plant. The size of the plant depends on the number of modules to be built simultaneously, each module requiring a 220 ft. x 220 ft. area. The water depth need not be more than 7 ft. and minimal pumping may be required by taking advantage of tides. Building is started by placing the lower, previously precast, spherical domes in saddle-type supports, then proceeds with casting the concrete walls of the buoyancy chamber, thus producing a watertight "vessel" with an open top. Once the concrete walls gain sufficient strength, the dry dock can be flooded and the completed portion towed to a

secondary precasting plant. This secondary precasting plant is visualized as a series of floating piers with the proper configuration to accommodate the floating module. Construction proceeds from these piers, by enclosing the buoyancy chambers with the top spherical domes, placing the columns, etc. The role of the secondary plant is threefold :

- a. It minimizes the required water depth in the dry dock; eliminates necessity for pumping.
- b. It minimizes the time to be spent in the dry dock.
- c. It allows larger tugboats to approach the completed module to be towed to site.

## 2. Towing

The completed module has to be towed from the secondary plant to its final location. The distance to be travelled may vary a great deal depending on the relative position of the fabrication and airport sites, but it is not expected to be more than 40 miles. Since the buoyancy chambers form a closed hull, each module can be towed along a diagonal of the 200 ft. x 200 ft. square. Tugboats with a power plant of 2,000 HP are sufficient. (Drawing 8). Towing speed varies from 2 to 6 knots according to the size of the tug. For reasons of safety, two boats are used, one for the actual towing and a second as a standby. It may also be possible to tow more than one module at a time, thus reducing the cost of the operation.

When the module arrives within 300 - 400 ft. of its final location, cables are attached to the module, the tugs leave, and the last phase of the towing operation begins.

### 3. The Final Approach - Module Alignment

Let us assume that some part of the structure is already anchored at the site and we consider now the procedure of adding a module to ones already in place. (Drawing 8).

Before the new module arrives to the site, all mass anchors and mooring cables in the surrounding area must be in place. The ends of the mooring cables are marked with buoys and can be picked-up from the water surface by the approaching module. (Drawing 9).

In order to minimize the danger of collision and drifting, there will be several winches placed on the deck. Cables running from these winches are connected to adjacent mooring cables and to the completed portion of the structure. The four cables which form the permanent anchor system of the module are hooked to ropes leading to winches at the four anchor points at the bottom of the buoyancy chamber. Once these connections are completed and the cables are taut, the tugs leave the site and the final 300 - 400 ft. approach is made by operating the winches placed on the deck.

In this manner the module may be maneuvered within 4 - 5 ft. of the fixed structure. At this time buoyancy chambers are flooded. The flooding operation is coordinated with positioning of the module to the proper elevation. This is attained by "pulling down" the module on the four permanent mooring cables. Of course, a positive



buoyancy is always maintained to ensure stability throughout the operation. Once the buoyancy chamber is completely submerged the operation becomes quite insensitive to wind and wave forces and contact between the new and the fixed modules can be made.

#### 4. Connection - Vacuum Chambers

The connection is performed with the aid of the vacuum chamber. (Drawing 7). The vacuum chamber consists of a male and a female element. The male element is built on one, the female on the adjoining module. The male element consists of two semi-circular 2'-0" thick, horizontally projecting reinforced concrete protrusions located at the top and the bottom of the exterior buoyancy chamber wall. Along the perimeters of the half circles there are two, pressurized 1'-0" diameter, rubber tubes embedded in the concrete as shown in Drawing 7. The two semi-circular tubes are connected by two vertical tubes of the same diameter, so as to form a closed loop. This loop is laid along the contours of a cylinder cut into half along its longitudinal axis. It is shown in isometric view on Drawing 3. The female element is a semi-cylindrical depression in the exterior buoyancy chamber wall of the adjacent module capable of receiving the male element.

After the final alignment of the fully-submerged buoyancy chamber is checked, contact between the new and the fixed modules can be made by mating the two elements of the vacuum chambers. To develop a thrust that will firmly stabilize the new module, a valve is opened which equalizes the pressure between vacuum and buoyancy chambers. The external hydrostatic pressure provides the necessary

thrust that locks the modules together. The thrust is 240 kips per (vacuum) chamber.

Once this temporary connection is completed, water is pumped out of the chambers. To make the final, permanent connection, a chute is lowered from the deck into the vacuum chamber and concrete is dropped in the prepared form around the dowels. (Drawing 7).

The vacuum chamber profile was developed to perform different functions at subsequent states of the assembly operation. At first the rubber loop serves the purpose of a bumper. By properly controlling the pressure in the tube, the impact of minor collisions can be absorbed. Once contact is made, the profile ensures self-locking in a horizontal plane. In the vertical direction, there is no need for such a device since accurate alignment can be achieved by adjusting the lengths of the mooring cables. When the interlocking force is activated by opening the valve, the tube functions as a watertight seal. Having completed the permanent connections, the rubber tubes are removed, and the structure is ready to receive the next module. This sequence continues to the completion of the entire airport. Finishing operations, erection of hangars and other facilities on and below deck, follow standard practice used on dry land. The bumper and vacuum chamber assembly could also be built as a separate unit. In this case the assembly would be removed after final connections are made and re-used.

## VIII QUANTITY AND COST ESTIMATES

Table IV provides quantity and cost estimates. Quantities are determined from actual material take-off of preliminary design plans and details, costs are estimated on the basis of current price levels of similar structural components commonly used in building construction.

The cost estimates are restricted to the construction of the platform with all necessary components and the surfacing of all areas. It does not include, however, passenger and cargo handling facilities, terminal buildings, POL, lighting and other NAVAID facilities.

Details of the quantities and unit and costs are given in Table IV for Module Type 1. This module is used for the construction of typical runway and taxiway sections, that is, on areas which are subject to aircraft loads. Other parts of the airport are constructed of Module Type 2, the configuration of which is identical to Type 1, except that it is of lighter construction and the unit cost per module is substantially lower as shown in Table IV. In addition to that, about 23% of the total surface of the airport could be eliminated on purely functional considerations corresponding to 350 Module Type 2 units. If these units are eliminated, the cost of the airport is reduced. The desirability of such open surfaces within the airport need to be further studied. At this time, therefore, the cost of the installation should be set as being between 1.1 to about 1.4 billion dollars.

The cost estimates, of necessity, are approximate. Actual cost will depend a great deal on the unit prices which prevail at the time of the construction. More reliable estimates will be obtained after detailed plans and specifications have been completed. It may be noted that a substantial part of the total cost consists of components (Items 1 to 6) which will be built by standard construction practices, on dry land, and the cost of these even from a preliminary design, can be established with a degree of confidence. These items also contribute the most significant amounts to the total cost. The remaining cost components (Items 7 to 9) refer to components and procedures connected with off-shore construction; they include the cost of transportation over water, the placement of mass anchors and mooring cables, and the positioning of the modules. These items, of course, require special consideration and, therefore, costs are subject to uncertainties not only because of the unusual nature of the operations but also because they are greatly affected by the actual location of the proposed airport and by the conditions which will be found below the ocean bottom.

Costs are not substantially affected by the depth of water. The items which are sensitive to this change, namely, the mooring cables, have a relatively small effect on the overall cost. The present costs are based on a depth of 300 ft. For depths greater than 500 ft., changes in the configuration may be necessary and cost variations would, therefore, become more pronounced.

The cost of transportation of the modules from the on-shore precasting plant to the site at high seas, and the cost of assembly are arrived at by considering the time spent by two 4,000 H.P. tugboats operating at a cost of \$2,200/day each.

Based on a distance of 30 nautical miles between the precasting plant and the site and a towing speed of 4 knots, the tugboat time breakdown is as follows :

Travel from base to precasting plant	1 hour
Rigging for towing	3 hours
Towing	7 hours
Positioning at site, assistance for assembly procedures	6 hours
Return to base	<u>5</u> hours
Total	22 hours

Thus, the total time spent is roughly one day per module, assuming two tugboats for the operation - one for the actual towing, the other as a stand-by. The cost of the transportation and assembly is  $2 \times \$2,200.00 = \$4,400.00$  per module. (The cost of additional equipment and manpower on the site is included in the unit price of materials). The cost of transporting and placing a mass anchor is estimated to be the same as that of a module.

It is clear from the above cost estimates that the cost of construction of a floating platform far exceeds that of the cost of an airport constructed on dry land. Such construction, therefore, will only be

undertaken if land-based facilities or facilities which are near the shore cannot be considered for various reasons. For purposes of comparison a parametric study was prepared, the results of which are presented in the curve shown on Fig. 4. The cost per square foot, as indicated on this graph, provides a very approximate comparison of cost as a function of depth of water. The costs refer to the construction of paved surfaces and the curve starts off with a cost of approximately \$2.00 per square foot on dry land, representing: cost of land, grading and paving. It is then assumed that up to a certain depth off-shore hydraulic fill will be used where this is technically and economically feasible. Beyond such a depth, pile construction is assumed. The pile-supported super-structure is assumed to be similar to the super-structure of the FLAIR platform.

The total weight of the platform is 16,000,000 tons, (excluding mass anchors), covering an area of 47,000,000 sq. ft. The average weight is 800 p.s.f. and the cost comes to about 4.5¢ per lb.

The fabrication proceeds from off- or on-site precasting plants and batching and mixing plants supplying the reinforced concrete components. These materials, together with the structural steel, are transported to the main module fabricating units located on the shore. Each such unit consists of 2 primary dry docks and 4 secondary floating docks. Each dock takes in an area of about 100,000 sq. ft. The cost of each unit is estimated at \$10,000,000.00 with a production capacity of 50 modules per year. Assuming that 15 such units are used, the entire platform can be completed in 4 years requiring a fixed investment of \$150,000,000.00 which is equivalent to \$50,000.00 investment per module. The 4-year

time estimate allows for simultaneous completion of the passenger,  
cargo and other operating facilities.

QUANTITIES AND COSTS 200 ft. x 200 ft. TYPE I MODULE IN PLACE

No.	Item	Material	Unit	Quantity	Unit Price	TOTAL
					\$	\$
1	6" Wearing Surface	Reinforced Concrete (Cast in Place)	sq. yd.	4,444	7.00	31,108.00
2	14" Deck Panels	Prestressed Concrete (Precast)	sq. yd.	4,444	50.00	222,200.00
3	Deck Framing Columns & Diagonals	Structural Steel	ton	864	400.00	345,600.00
4	Buoyancy Chamber Domes	Prestressed Concrete (Precast)	sq. yd.	10,500	45.00	472,500.00
5	Buoyancy Chamber Walls	Reinforced Concrete (Cast in Place)	cu. yd.	3,000	120.00	360,000.00
6	Mooring Cables	Zinc Coated Marine Cable	lin. ft.	1,020	6.00	6,120.00
7	Mass Anchor "box"	Reinforced Concrete (Cast in Place)	cu. yd.	260	120.00	31,200.00
8	Miscellaneous					60,000.00
9	Transportation and Assembly					8,800.00
	TOTAL					\$ 1,537,528.00

No.	Cost per Module	Total
600	1,537,528.00	922,516,800.00
576	800,000.00	460,800,000.00
	Max. Cost	\$1,383,316,800.00 (\$29.40 per sq.ft.)
350	800,000.00	280,000,000.00
	Min. Cost	\$1,103,316,800.00 (\$33.40 per sq.ft.)



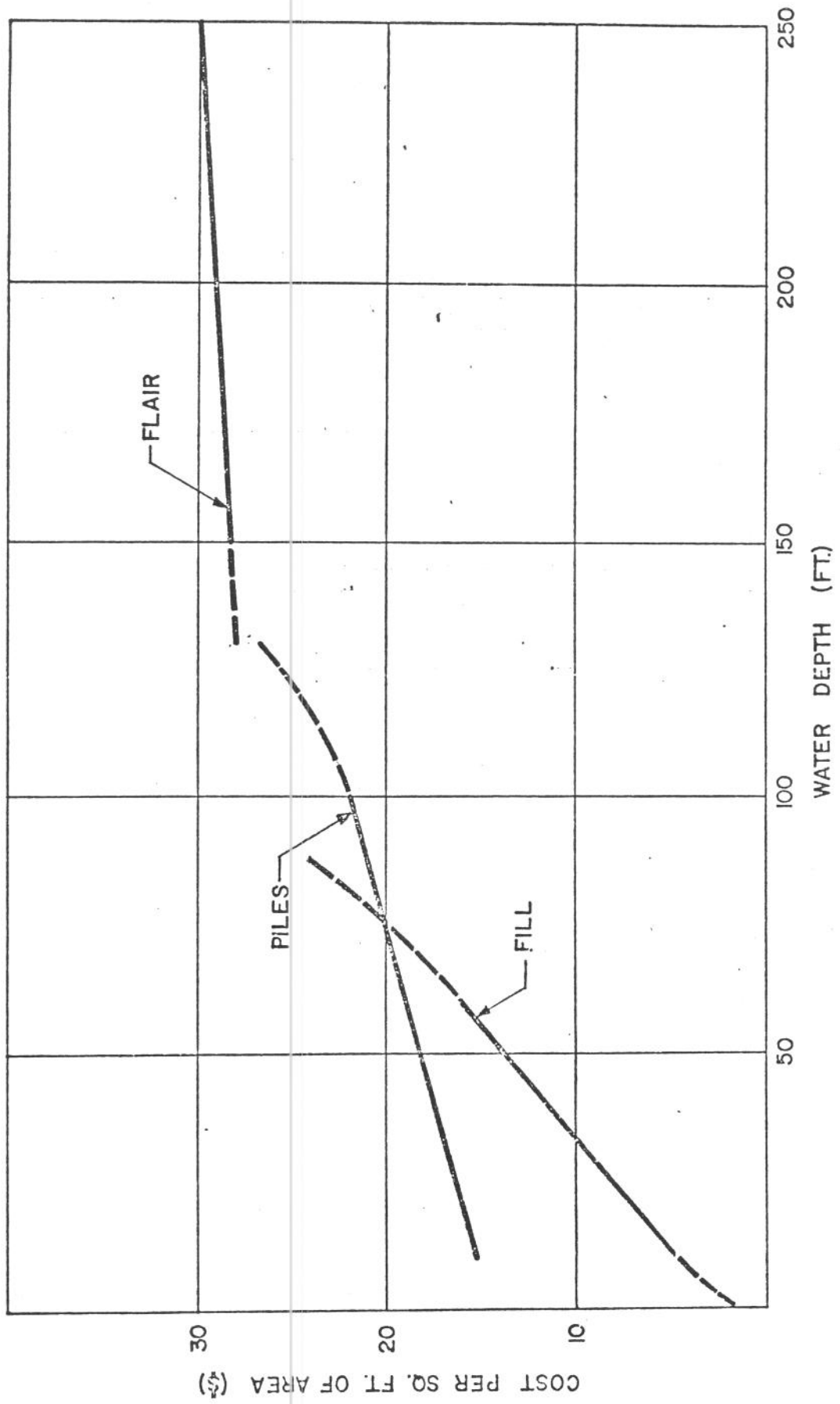

FIGURE 4. - COST VS. DEPTH

## IX CONCLUSIONS

The preliminary design demonstrates the feasibility of constructing an ocean-based floating airport within the constraints of presently available technology. The average cost per square foot of surface area is about \$30.00. This cost includes materials, construction and positioning of the platform with finished runways, taxiways, shoulders, etc., but excludes terminal buildings, all mechanical and electronic equipment. The total cost of the airport as outlined in this report, is 1.1 to 1.4 billion dollars.

The significant features of the design are :

1. The effect of waves on the buoyant hull are reduced to negligible levels by completely submerging the buoyant elements.
2. Complete passenger and cargo processing facilities are provided below the framed deck, facilitating multi-level passenger handling at minimal cost resulting in efficient terminal design.

The structure consists of completely self-sufficient modules providing maximum flexibility in design and later expansion. Fig. 5 shows examples of different airport configurations.

Throughout the development of the concept, problems facing the designers and planners were exposed. Many of these cannot be answered with sufficient precision within the scope of this study and they designate the following areas for further research :

1. Analytical and model studies of environmental forces and interaction with the structure.
2. Determination of corrosion rates of existing building materials in marine environment; search for reliable and economical protective measures.
3. Field testing of the module assembly procedures.

Beyond the problems facing the designers, other questions need also be answered to prove the viability of the ocean-based airport concept.

Foremost of these is the airport-to-shore transportation system.

Since air transportation is an important phase of our national economy, its future forms and development are inseparable from basic economic trends. Population growth, air transport demand, growth pattern of our future cities, technological innovations, etc., become decisive factors.

The development of airports within the urban fabric is increasingly difficult; therefore, an ocean-based facility may be an attractive alternative. Rapidly advancing oceanographical technology certainly points towards the increasing exploitation of the vast potentials of the seas. The FLAIR study is addressed to these potentials.

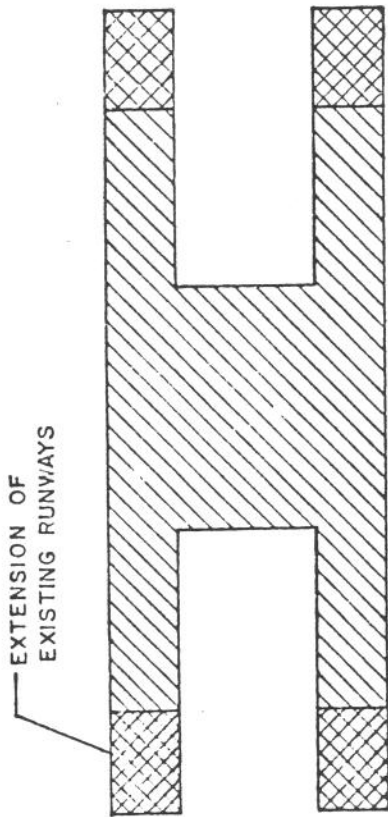

**SCHEME 1**

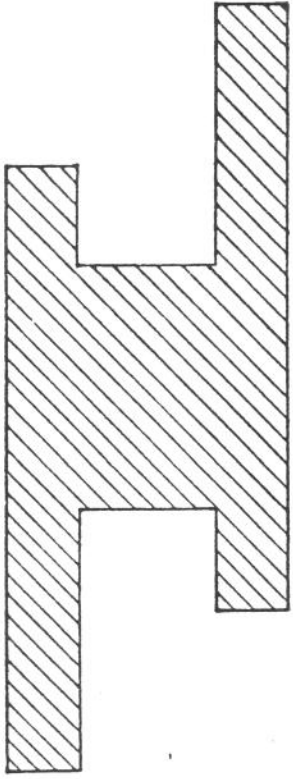

**SCHEME 2**

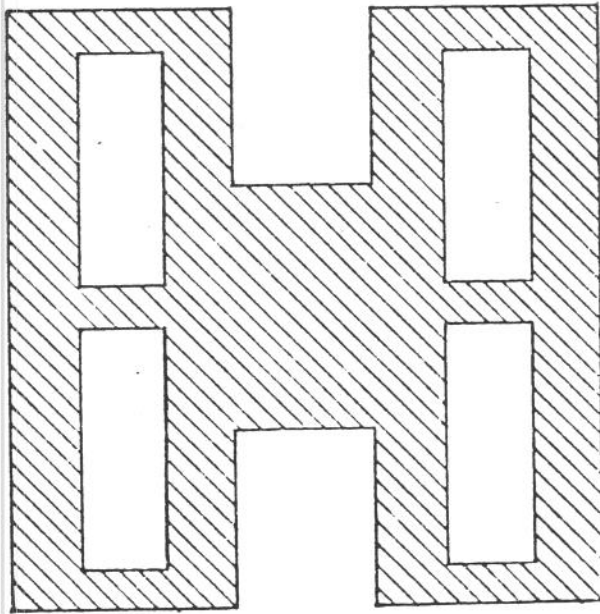

**SCHEME 3**

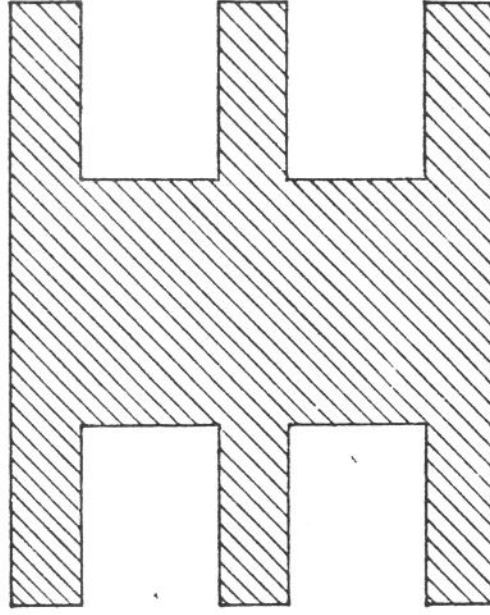

**SCHEME 4**

FIGURE 5.- AIRPORT CONFIGURATIONS.

REFERENCES

- Ref. 1 Garwin, Richard L., "Some Aspects of a Vertical and Short Take-Off and Landing System for Commercial Aviation". IDA/JASON. Unpublished paper.
- Ref. 2 Armstrong, E.R., "The Seadrome Project for Transatlantic Airways". Wilmington, Del., 1943.
- Ref. 3 Carrive F. and Julien B., "Designing Highly Stable Floating Platforms". Ocean Industry, August 1969.
- Ref. 4 Wakeman, C.M., Dotzweiler, E.V., Storer, H.E., Whiteneck, L.L., "Use of Concrete in Marine Environments". ACI Journal, April 1968.
- Ref. 5 "U.S.S. Mariner Steel Sheet and H-Piling, An Answer to Sea Water Corrosion". U.S.Steel.
- Ref. 6 "747 Airplane Characteristics". Boeing Commercial Airplane Division, March 1968.
- Ref. 7 "Boeing 747 Passenger Airplane". Boeing Commercial Airplane Division, March 1969.
- Ref. 8 Stevens, W.C., Yang, N.C., Kapp, M.S., Lier, A., Fasullo, E., "The La Guardia Airport Runway Extensions", Transactions of the New York Academy of Sciences. Ser. II, Vol. 27, No.3. January 1965.
- Ref. 9 "Rules for Building and Classing Off-Shore Mobile Drilling Units". American Bureau of Shipping, 1968.
- Ref.10 "Wind Forces on Structures", Transactions of the American Society of Civil Engineers, Vol. 126, 1961.
- Ref.11 Schlichting, Herman, "Boundary Layer Theory", McGraw-Hill, 1968.

## Appendix A

### Massless load travelling on a Timoshenko beam supported by an elastic foundation.

#### 1. Introduction

In order to establish the behaviour of a floating airport under the action of a plane taking-off from or landing on it, one must investigate the behaviour of a plate on elastic foundation under the action of a concentrated load of variable intensity moving on it with variable speed. This Appendix gives the solution to an analogous, but simplified, problem in order to emphasize one of its essential features: the difference in the runway deflection depending on whether the plane velocity is sub-critical or super-critical.

To this purpose, the simplified problem considered is that of a massless, constant load  $P$  travelling with constant speed  $v$  on an infinite Timoshenko beam, supported by a Winkler foundation of constant modulus and developing viscous damping through radiation in water.

#### 2. The Timoshenko beam on elastic foundation

The dynamic equation of a Timoshenko beam is<sup>(1)</sup>:

$$B \frac{\partial^4 w}{\partial x^4} + \frac{m}{g} \frac{\partial^2 w}{\partial t^2} - \frac{\rho I}{g} \left(1 + \frac{E}{k'G}\right) \frac{\partial^4 w}{\partial x^2 \partial t^2} + \frac{\rho I}{g} \frac{\gamma}{gk'G} \frac{\partial^4 w}{\partial t^4} = 0, \quad (1)$$

where:

$B \equiv EI$  = flexural rigidity of beam

$m$  = mass of beam per unit length

$\rho$  = beam density

$I$  = moment of inertia of beam

$E, G$  = Young and shear moduli of beam

$k'$  = shape factor of beam cross-section

$k$  = spring constant of foundation

$w$  = displacement of beam normal to beam axis

$x$  = longitudinal coordinate along beam axis

$t$  = time.

In order to take into account the viscous damping due to radiation in water a term :

$$\rho_w c_w b \frac{\partial w}{\partial t} \quad (2)$$

is added to the left-hand member of eq. (1), in which :

$\rho_w$  = water density

$c_w$  = speed of sound in water

$b$  = beam width.

Since the beam is assumed to be of infinite length, we will also assume that the load  $P$  has been travelling on it for a long time and limit the solution of the problem to a steady-state solution :

$$w(x,t) = w(x-vt). \quad (3)$$

Letting:

$$z = x-vt, \quad (4)$$

$$\frac{d(\quad)}{dz} = (\quad)', \quad (5)$$

the steady-state equation of the problem thus becomes :

$$\begin{aligned} & \left[ 1 - \frac{\rho v^2}{E} \left( 1 + \frac{E}{k'G} \right) + \frac{\rho v^2}{E} \frac{\rho v^2}{k'G} \right] w^{iv} + \\ & + \frac{mv^2}{EI} w''' - \rho_w c_w \frac{bv}{EI} w' + \frac{k}{EI} w = 0. \end{aligned} \quad (6)$$

It may be checked that for a concrete beam and for take-off or landing speeds of the order of 200 mph, the terms representing the effects of rotatory inertia and shear deformation are negligible so that eq.(6) reduces to :

$$w^{iv} + \frac{mv^2}{EI} w''' - \rho_w c_w \frac{bv}{EI} w' + \frac{k}{EI} w = 0. \quad (7)$$

### 3. Critical Speed

In the absence of viscous damping, eq.(7) becomes :

$$w^{iv} + \frac{mv^2}{EI} w''' + \frac{k}{EI} w = 0 \quad (8)$$

and was shown by G. Krall<sup>(2)</sup> to have a solution, continuous at  $z=0$  together with its first and second derivatives and with a third derivative satisfying the shear condition :

$$EI w'''' \Big|_0^+ = P, \quad (9)$$

of the form :

$$w(z) = A \phi(z), \quad (10)$$



where :

$$A = \frac{P}{4EI(\alpha^2 + \gamma^2)},$$

$$\alpha = \lambda\sqrt{1-\beta}, \quad \gamma = \lambda\sqrt{1+\beta}, \quad \lambda^4 = \frac{k}{EI}, \quad \beta = \frac{v^2}{c^2}, \quad c^4 = \frac{4kEI}{m^2}, \quad (11)$$

and :

$$\phi(z) = e^{-\alpha z} \left[ \frac{1}{\alpha} \cos \gamma z + \frac{1}{\gamma} \sin \gamma z \right]. \quad (12)$$

The solution of eqs. (10), (11), (12) is valid for :

$$z > 0 \quad \text{and} \quad \beta \leq 1. \quad (13)$$

It is seen from eqs. (10) to (13) that for  $\alpha = 0$ , i.e. for  $\beta = 1$  or :

$$v^2 = c^2 = \frac{2}{m} \sqrt{kEI} \quad (14)$$

the solution blows up. The velocity  $v_{cr} = c$ , defined by :

$$v_{cr}^2 = \frac{2}{m} \sqrt{kEI} = c^2, \quad (15)$$

is called the critical velocity of the beam. A  $v < c$  will be called sub-critical; a  $v > c$  will be called super-critical.

#### 4. Beam behaviour at sub-critical velocities

From the solutions (10) - (13), valid for  $\beta < 1$ , i.e. for sub-critical velocities, it is found that :

$$w'(z) = \frac{dw}{dz} \equiv \frac{\partial w}{\partial x} = -A(\alpha^2 + \gamma^2)e^{-\alpha z} \sin \gamma z. \quad (16)$$

If we call  $x = 0$ , the position of the load  $P$  at  $t = 0$ , the load  $P$  is found to be always at the value  $z = 0$  of the Galilean coordinate  $z = x - vt$  and, by eq.(16), the slope of the deflected beam under the load is zero. Since the deflected curve  $w$  may be proved to be symmetrical about  $z = 0$ , one concludes that the load travels horizontally remaining in the trough of the deflection curve and no energy input is required to maintain the steady-state motion.

#### 5. Beam behaviour at super-critical velocities

To solve eq.(8) for super-critical velocities it is convenient to write it, by means of (11), in the form :

$$w^{iv} + 4\beta\lambda^2 w'' + 4\lambda^4 w = 0. \quad (17)$$

The characteristic equation of eq.(17) has roots  $m$  defined by :

$$m^2 = 2\beta\lambda^2 \left[ -1 \pm \sqrt{1 - \frac{1}{\beta^2}} \right] \quad (< 0 \text{ for } \beta > 1)$$

and given by :

$$m_{1,2} = \pm \alpha i, \quad m_{3,4} = \pm \gamma i, \quad (18)$$

where :

$$\alpha = \lambda\sqrt{2\beta} \left[ 1 + \sqrt{1 - \frac{1}{\beta^2}} \right]^{1/2}, \quad (\alpha > \gamma > 0) \quad (18a)$$

$$\gamma = \lambda\sqrt{2\beta} \left[ 1 - \sqrt{1 - \frac{1}{\beta^2}} \right]^{1/2}.$$

The solution  $w(z)$  vanishing at  $\pm\infty$  and valid for  $z < 0$  and  $z > 0$  may be shown to be :

$$w_l(z) = C_1 \cos \gamma z + C_2 \sin \gamma z, \quad (z < 0) \quad (19)$$

$$w_r(z) = C_3 \cos \alpha z + C_4 \sin \alpha z. \quad (z > 0)$$

The solutions  $w_l(z)$  and  $w_r(z)$ , satisfying continuity conditions at  $z=0$  for  $w$  and for its two first derivatives and the shear condition of eq.(9) for its third derivative, are :

$$w_l(z) = -\frac{P}{EI} \frac{\sin \gamma z}{\gamma(\alpha^2 - \gamma^2)}, \quad (20)$$

$$w_r(z) = -\frac{P}{EI} \frac{\sin \alpha z}{\alpha(\alpha^2 - \gamma^2)}$$

from which :

$$w'(0) = -\frac{P}{EI} \frac{1}{\alpha^2 - \gamma^2} \quad (21)$$

The load  $P$ , travelling along the positive  $x$ -axis, has a positive horizontal component  $H = Pw'(0)$  and moves "up-hill" on the deflected beam. The energy input needed to maintain the steady-state motion is given by :

$$H \frac{\partial w}{\partial t} .$$

## 6. Influence of damping

Numerical solutions of eq.(7) for sub-critical velocities have shown that the energy input required to maintain a steady-state deflection

first increases and then decreases with increasing damping, while the beam deflection under the load,  $\delta$ , decreases with increasing damping, as indicated by the results of Table I.

TABLE I

$\frac{\rho_w c_w bv}{EI}$	$\delta$	H
0	3871	0
$.97 \times 10^{-6}$	3861	63
$.97 \times 10^{-2}$	65	709
$.97 \times 10$	0.066	7

For super-critical velocities the energy input decreases with increasing damping while the deflection under load first grows and then decreases, as shown by Table II.

TABLE II

$\frac{\rho_w c_w bv}{EI}$	$\delta \times 10^4$	H
$0^{(*)}$	$0^{(*)}$	6,636 <sup>(*)</sup>
$.29 \times 10^{-8}$	0.0018	6.590
$.29 \times 10^{-5}$	1.8	6,616
$.29 \times 10^{-1}$	20.8	358
$.29 \times 10^{-2}$	0.022	3.4

(\*) This case is obtained as the limit solution for  $\frac{\rho_w c_w bv}{EI}$  approaching zero and is the undamped deflection obtained in Section 5.

7. Bibliography

1. S. Timoshenko. Vibration problem in Engineering. p.331.
2. G. Krall. "Sul problema centrale della dinamica dei ponti",  
Rendiconti, Acc. Naz. Lincei. Serie VIII; Vol. XIX,  
fasc. 6 (Dec. 1955). Vol. XXXVIII, fasc. 6 (June 1965).  
Vol. XXXIX, fasc. 1-2 (July-August 1965).

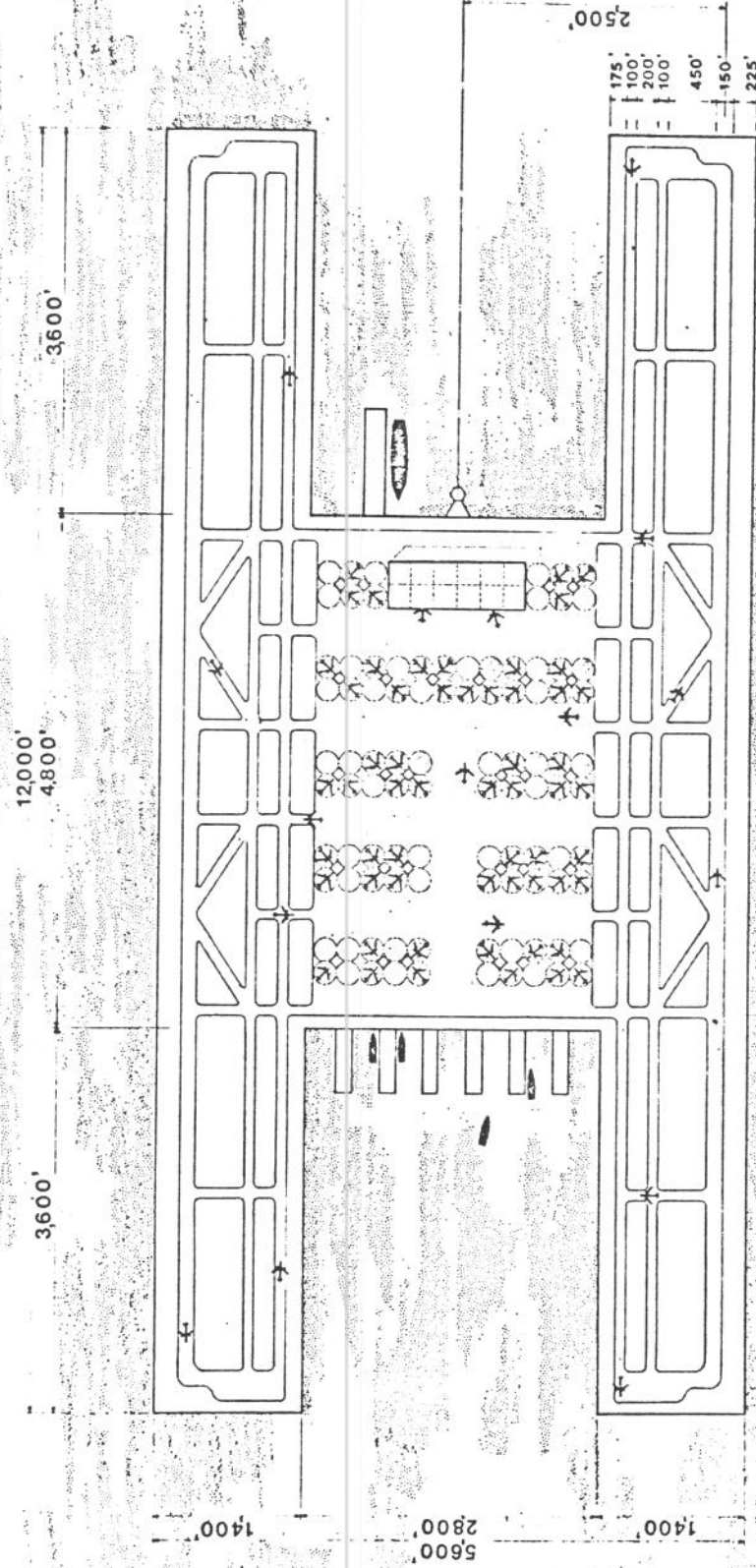
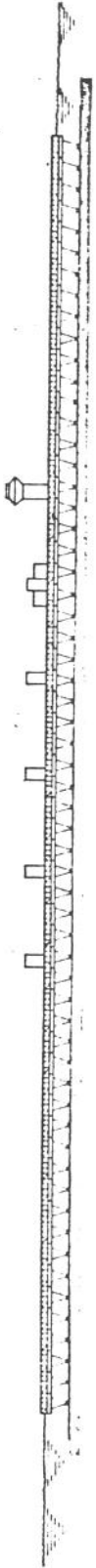

	AREA (ACRES)	CAPACITY
RUNWAYS	80	100 AIRCRAFT MOVEMENTS PER HOUR
TAXIWAYS	173	60 GATE POSITIONS
TERMINALS AND PARKING	262	36 PARKED PLANES
HANGARS	19	12 MAINTENANCE HANGARS
DECK AREA EXPOSED TO AIRCRAFT LOADING	534	
SHOULDERS AND MISCELLANEOUS	546	
<b>TOTAL</b>	<b>1,080</b>	

**FLAIR**  
 FLOATING AIRPORT  
 PAUL WEIDLINGER  
 CONSULTING ENGINEER



**PLAN**



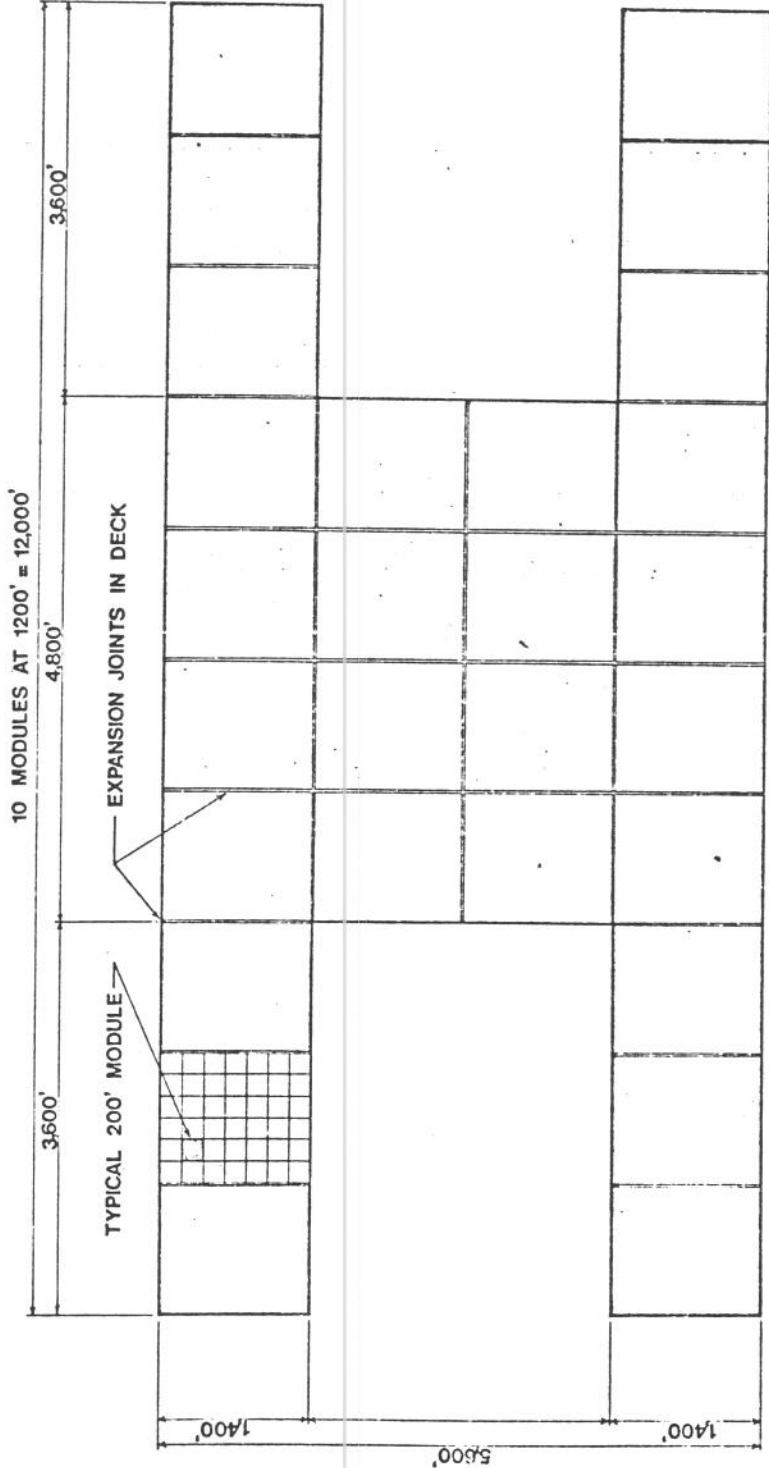

## SUB-DIVISION OF STRUCTURE

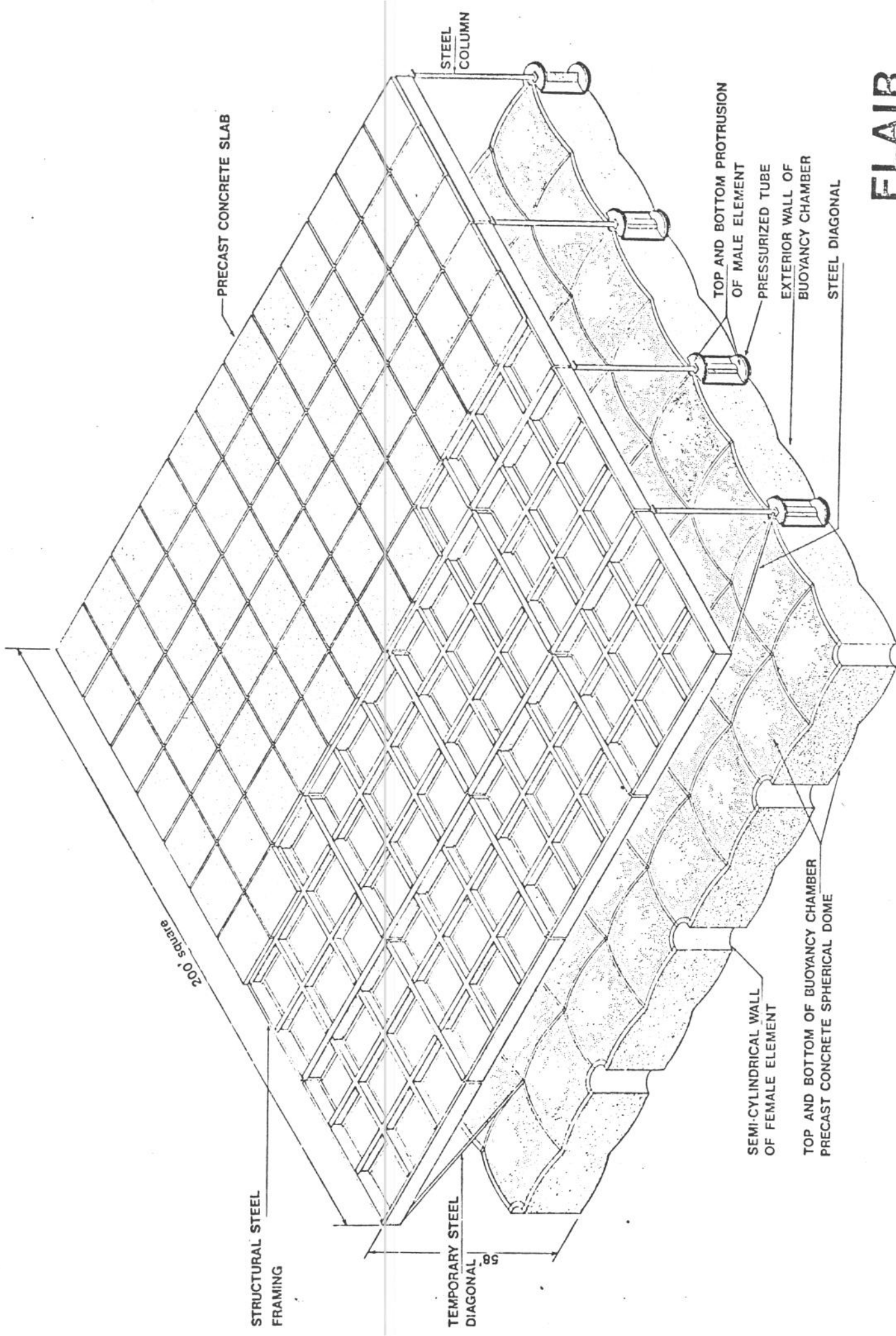

**FLAIR**

FLOATING AIRPORT

PAUL WEIDLINGER  
CONSULTING ENGINEER



**MODULE**



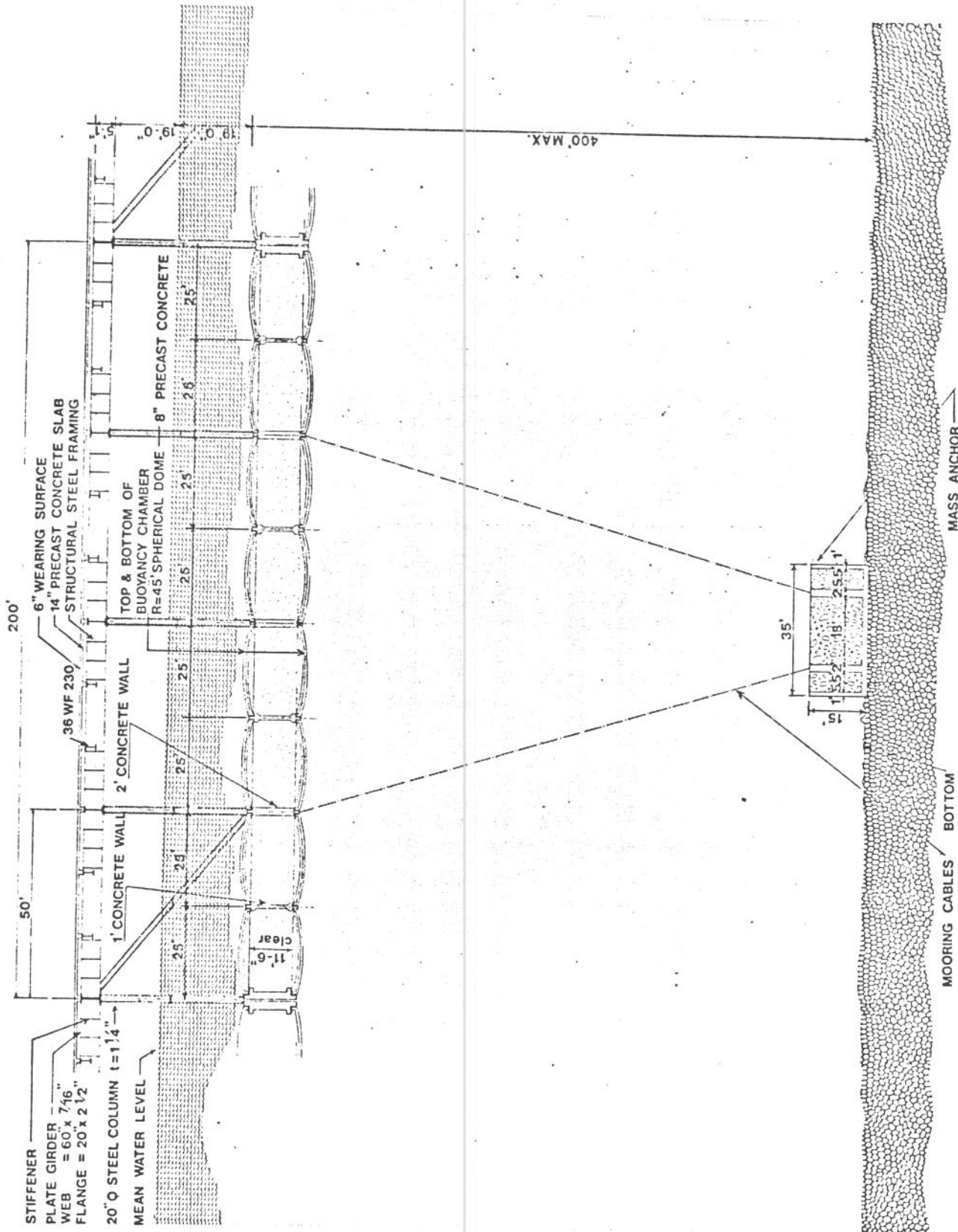

**FLAIR**  
 FLOATING AIRPORT  
 PAUL WEIDLINGER  
 CONSULTING ENGINEER



**TYPICAL CROSS SECTION**

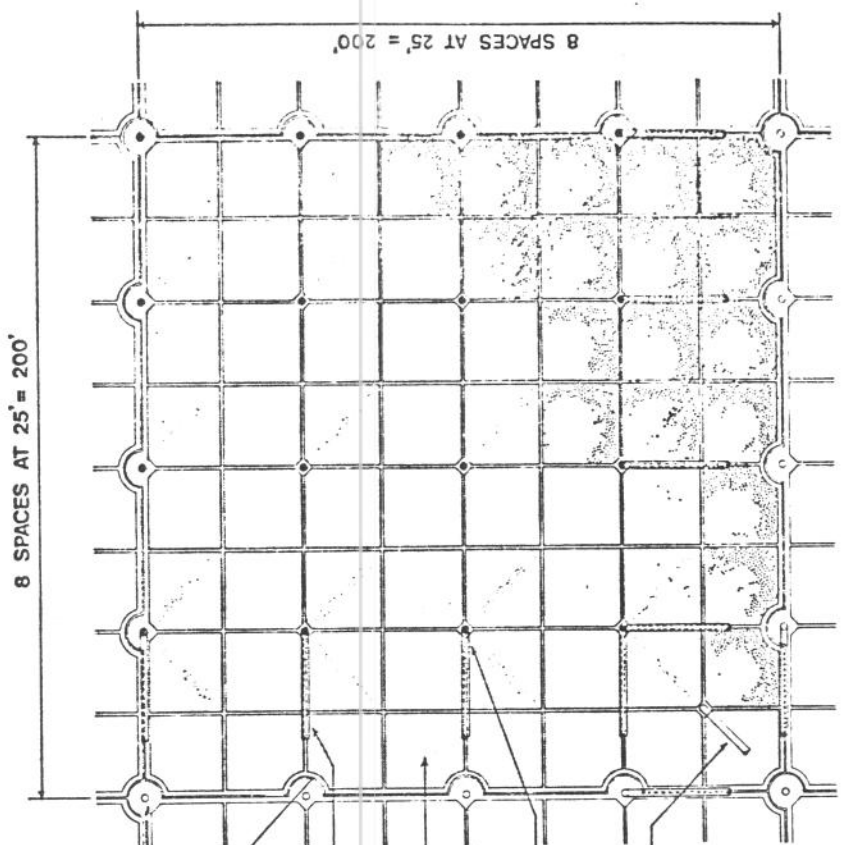

# SUB-STRUCTURE FLAIR

FLOATING AIRPORT  
PAUL WEIDLINGER  
CONSULTING ENGINEER

0 5' 10' 15' 20'

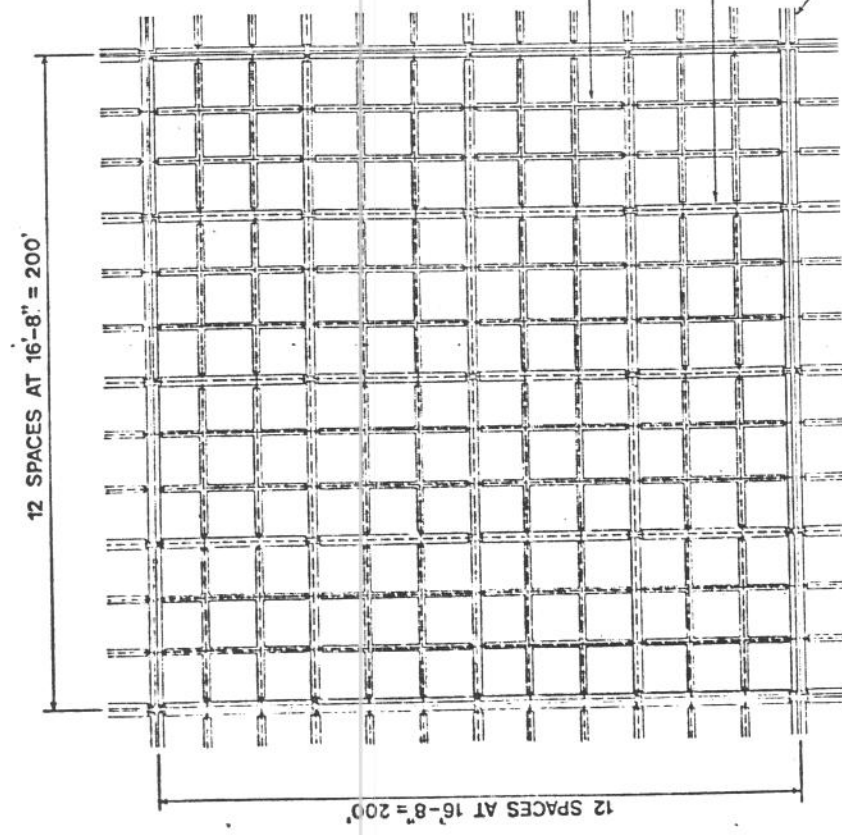

# DECK FRAMING

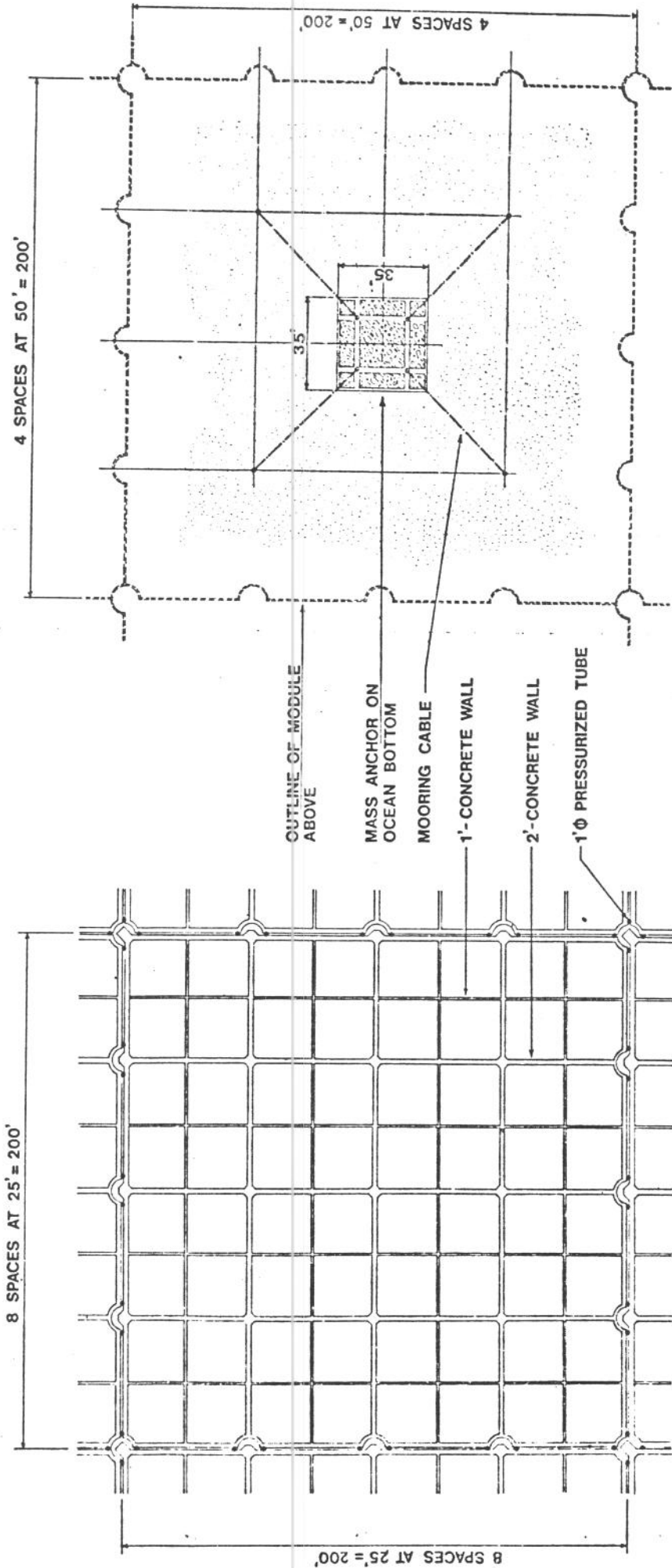

## BUOYANCY CHAMBER WALLS

## ANCHORAGE SYSTEM

**FLAIR**

FLOATING AIRPORT

PAUL WEIDLINGER  
CONSULTING ENGINEER

0 5' 10' 15' 20'



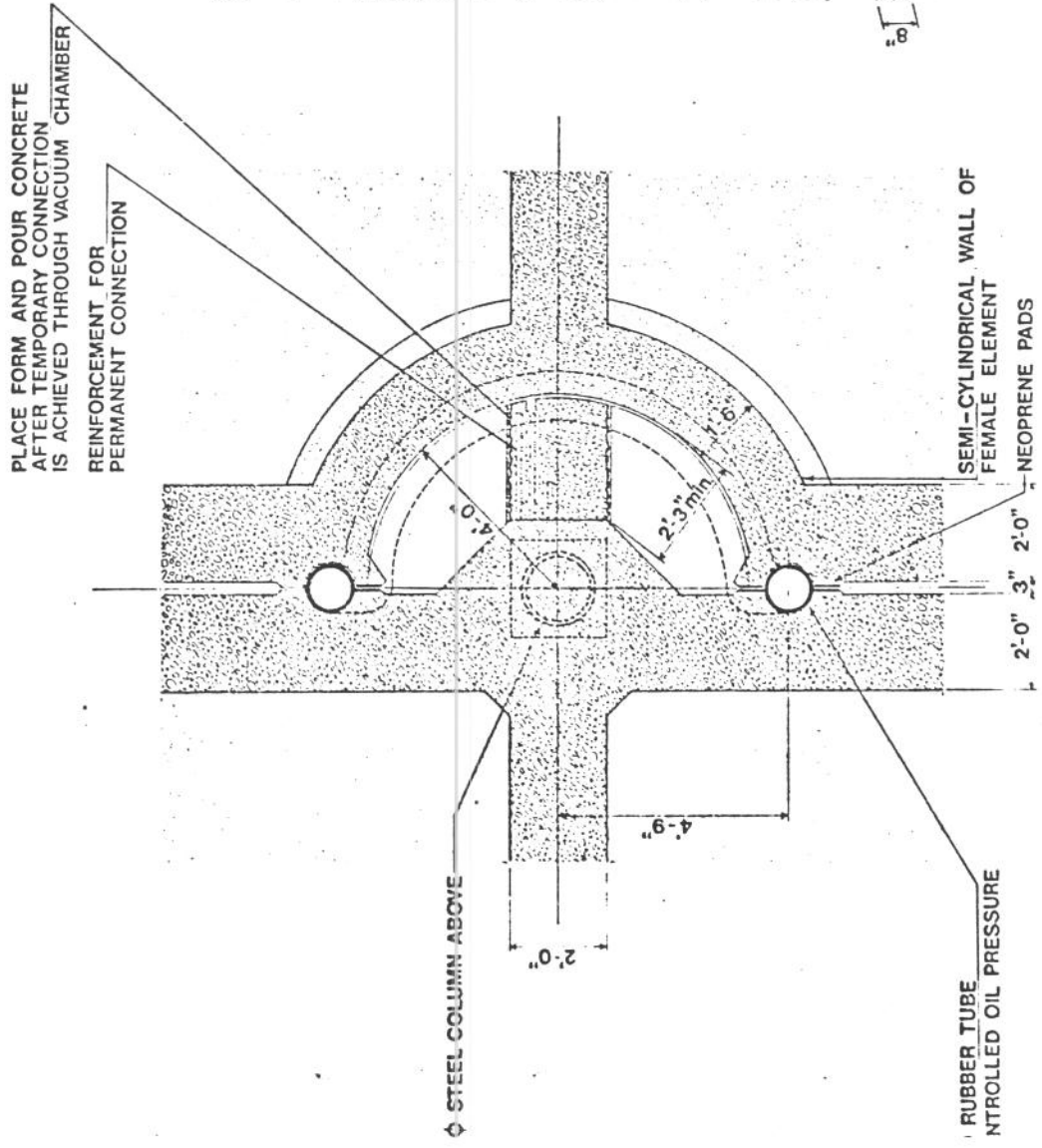
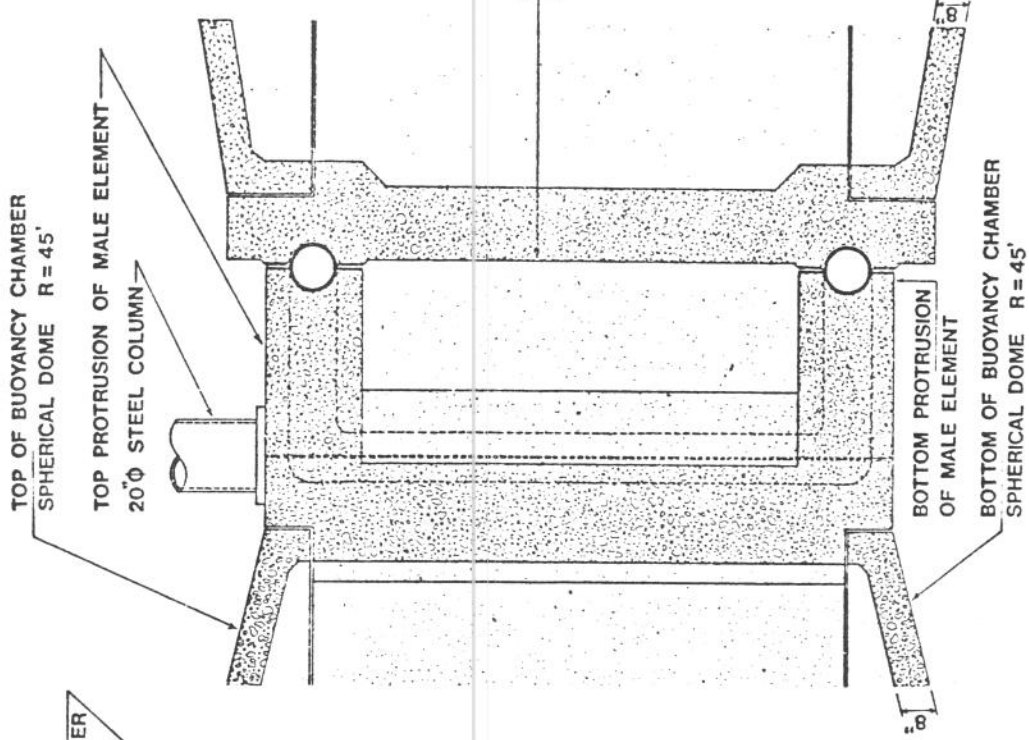

VERTICAL SECTION

HORIZONTAL SECTION

VACUUM CHAMBER

**FLAIR**  
 FLOATING AIRPORT  
 PAUL WEIDLINGER  
 CONSULTING ENGINEER



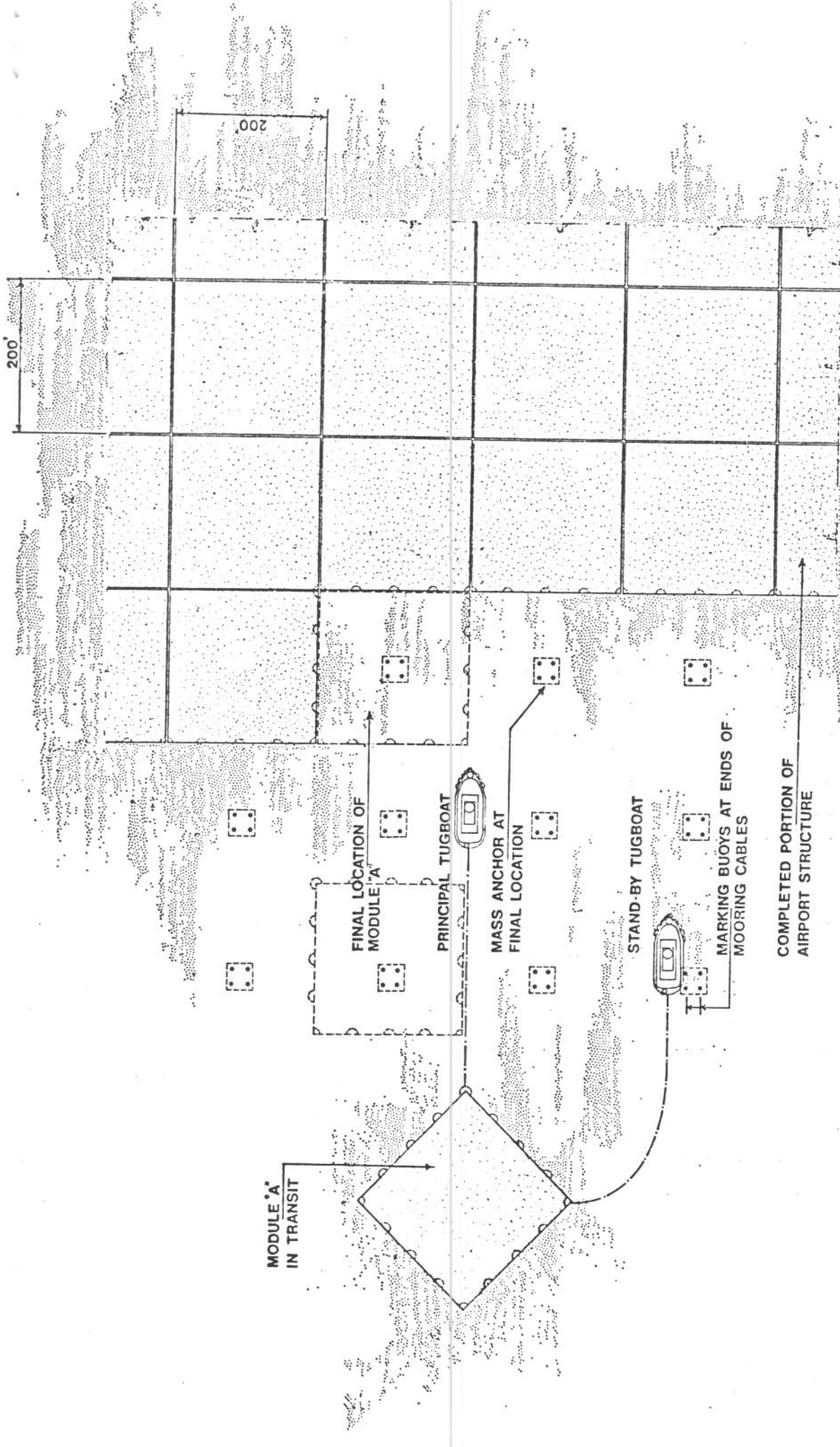

# FLAIR

FLOATING AIRPORT

PAUL WEIDLINGER  
CONSULTING ENGINEER



0 20' 40' 60' 80'

## APPROACH TO SITE



COMPLETED PORTION OF AIRPORT STRUCTURE

200'

200'

MODULE 'A'

MARKING BUOYS AT ENDS OF MOORING CABLES

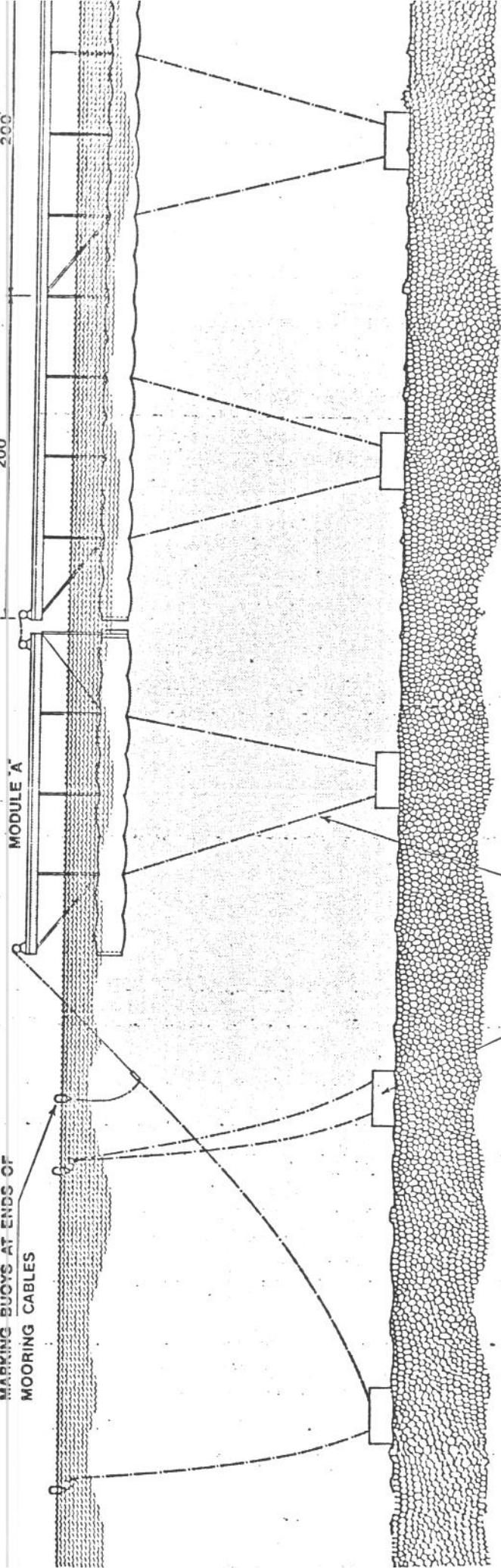

MASS ANCHOR

ACTIVE CABLES - MODULE ALIGNMENT BEFORE FINAL CONNECTION

**FLAIR**

FLOATING AIRPORT

PAUL WEIDLINGER  
CONSULTING ENGINEER

0 10' 20' 30' 40'

**MODULE ALIGNMENT**

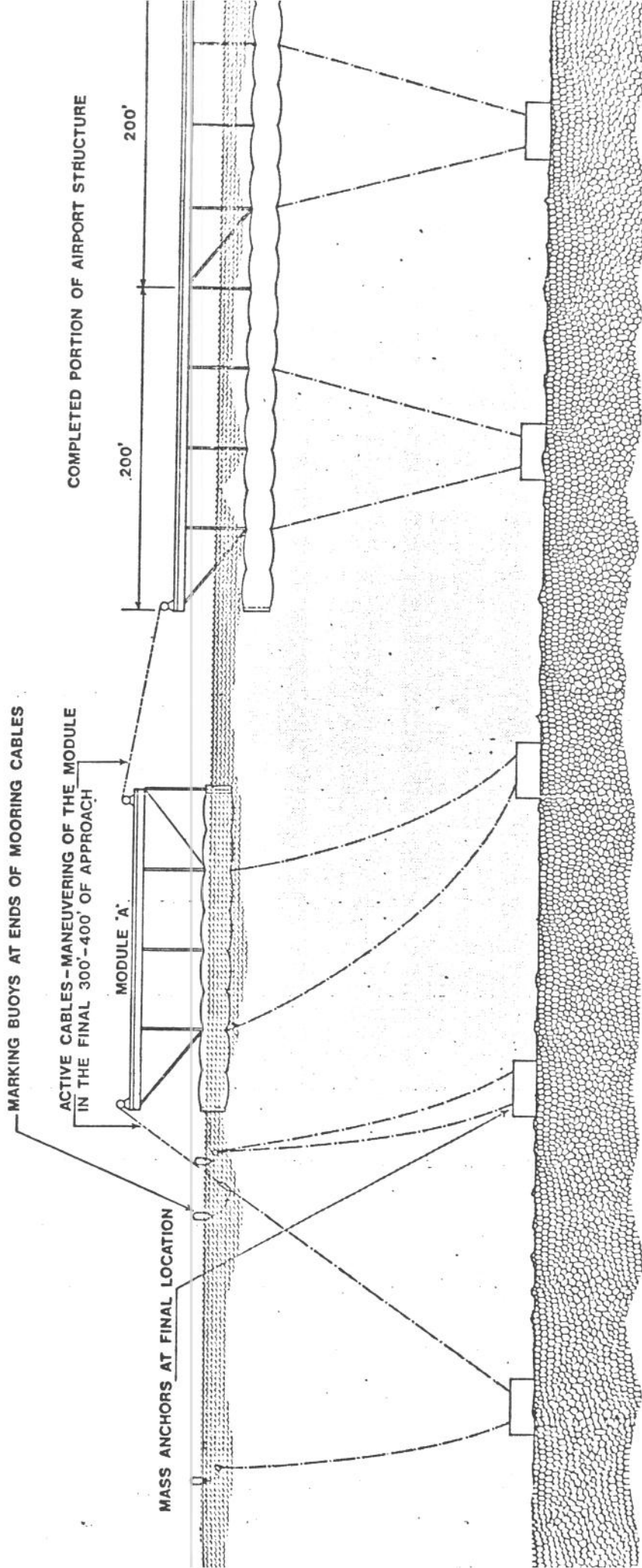

# MANEUVERING BY CABLES

**FLAIR**  
 FLOATING AIRPORT  
 PAUL WEIDLINGER  
 CONSULTING ENGINEER

